

Nexus[®] 1500+

**POWER QUALITY METER WITH
PHASOR MEASUREMENT UNIT**



Advanced Metering and Communication

- Constant Calibration™ Architecture Self-calibrates Every 10 Seconds
- Meets Critical Metering Needs with 0.06% Accuracy in Energy Metrology
- Resilient Cyber Security™ Encryption
- Six Available Communication Ports, Including Dual Ethernet Ports
- Ethernet Configurable Port Services Control
- PMU Functionality Supports Synchrophasor Applications
- Communication Protocols Include Modbus, DNP3, IEC 61850, GOOSE Messaging, SNMP, and IEEE 1588 PTPv2
- Color Touchscreen Display



Superior Recording and Power Quality Analysis

- Certified IEC 61000-4-30 Class A Ed. 3 Power Quality Measurement
- IEC 61000-4-15 Class A Flicker Measurement
- IEC 61000-4-7 Class A Harmonics Measurement
- Customized EN 50160 Power Quality Reporting
- IEC 62586-2 PQI-A Device Classification
- 50 MHz Transient Capture Speed
- IEEE C37.118.1-2011/.1a 2014 Compliant Synchrophasor Data
- Up to 4 GB of Memory
- Perfect for Co-generation and Independent Power Providers
- Supports Substation Automation, Grid Monitoring, and Distribution Substation Reliability Measurements

Introduction

The industry-leading Nexus® 1500+ meter has extensive features that make it the ideal choice for your power system management needs.

- Certified IEC 61000-4-30 Class A Ed. 3 power quality measurements provide full reporting of your system’s power quality conditions.
- 50 MHz transient recording captures events that lower speed recorders miss.
- Customizable EN 50160 reporting to meet any jurisdictional requirement.
- Auto-calibrating architecture ensures the meter maintains its high accuracy, providing precision measurements for your critical metering applications.
- PMU functionality enables real time grid monitoring.
- Resilient Cyber Security™ protects your metering data.

Highly Accurate Energy Metrology

Accuracy of your meter readings is of utmost importance. The 1500+ meter has advanced metrology that provides:

- Measurements that exceed the ANSI C12.20 0.1 CL and IEC 62053-22 0.2S standards.
- An energy class accuracy of 0.06%, with typical shipping accuracy of 0.02%.
- Two front test pulses for quickly determining meter accuracy.
- A real time clock accurate to 3.5 ppm, with less than ten seconds per month drift.

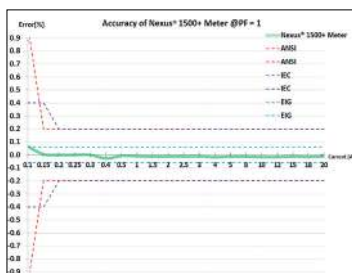

Typical 0.02% Accuracy Over Full Range

See the Nexus® 1500+ meter’s User Manual for accuracy details.

Constant Calibration™ Architecture Increases the Stability of Measurement Accuracy

The Nexus® 1500+ meter’s built-in auto-calibration technology, Constant Calibration™ architecture, is ideal for critical metering, such as high loads and large energy applications, where small errors make a big difference in costs. Features include:

- Calibrating the incoming signal every ten seconds using a separate calibration channel. This rapid auto-calibration ensures that the meter experiences minimal drift in accuracy over both time and temperature.
- The meter’s readings stabilize within ten seconds of powering up.
- Once installed, the meter maintains its precise accuracy throughout its operation range, even if temperature conditions are not ideal.

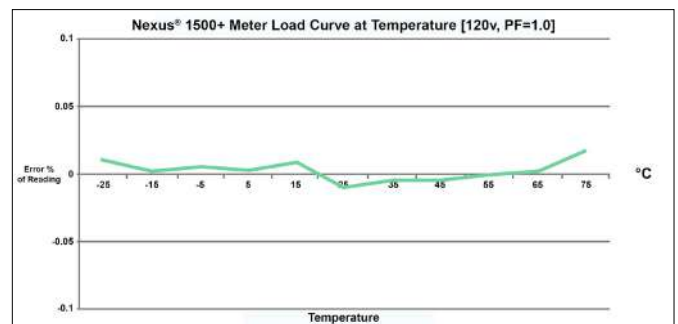

Drift Over Temperature

Meter Maintains Accuracy Over Changing Temperature

High-speed Primary Frequency Control

The Nexus® 1500+ meter provides a one cycle high-speed frequency reading, with a frequency resolution of better than 10 mHz. This feature is designed for primary frequency control, to maintain stability and to balance power generation and load consumption in the grid.

Advanced Revenue Meter for Primary Loads

- Full four quadrant metering.
- Energy load profiling: log virtually unlimited historical trending.
- Transformer and line loss compensation for iron/copper and total substation losses.
- CT/PT compensation corrects for errors in current and voltage transformers.
- Load aggregation/universal metering: aggregate or accumulate different loads with pulse inputs; utility products such as gas and water can also be accumulated.
- MV90 support.
- Identify number of capacitors needed, peak inefficiencies, etc., with coincidental readings, e.g., PF or VARs at time of peak demand.

System Events Logging (Anti-tampering)

The System Events log gives you extensive usage information for detection of unauthorized access. The meter records:

- Resets.
- Programming changes.
- Password access changes.
- Log downloads.
- Meter serial number change.
- Time changes.
- Power up/down.
- Change of firmware.
- System initialization problem.
- V-Switch™ key change.

Test Mode and Energy Presets

- Use the meter's test mode to verify accuracy without disturbing load profiling or demand recording.
- Energy preset lets you swap a new meter for one being removed for testing and verification. Download the energy accumulator register values and upload them to the new meter.

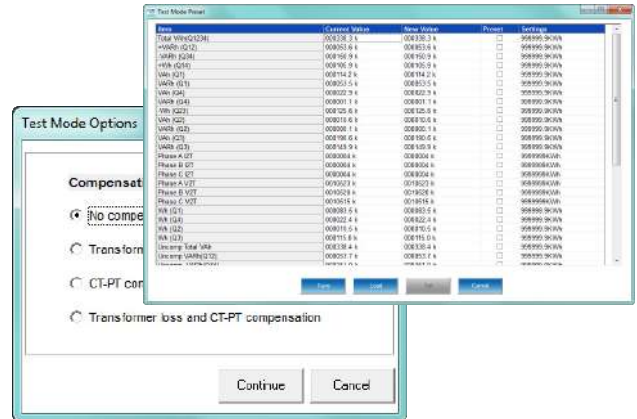

Perpetual Time of Use for Complex Metering

Set up multiple tariffs that meet any contractual obligation with the Nexus® 1500+ meter's perpetual time of use (TOU) calendar. You program the calendar only one time unless your requirements change. Use your TOU calendar for any energy parameter, stored data from pulses, or RTU Master readings.

- Up to four customizable seasons.
- Flexible billing periods/rates/holidays/schedules.
- Cumulative and continuous cumulative demand.

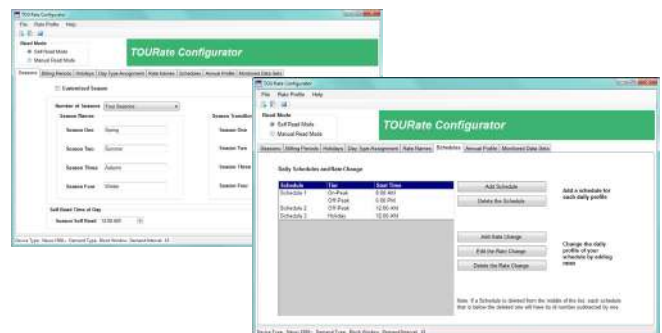

Power Quality Recorder with 50 MHz Transients

With EIG's Nexus® 1500+ meter you have one of the industry's highest speed fault and voltage disturbance recorders. The meter's 50 MHz transient recorder captures events that lower speed recorders may miss. Perform detailed and extensive forensic engineering analysis to develop a comprehensive picture of voltage reliability and power quality. Identify power quality problems, including harmonics, flicker, unbalances, transients, changes in frequency, sags, swells, and outages.

Certified IEC 61000-4-30 Class A Ed. 3 Power Quality Meter

- The Nexus® 1500+ meter supports the most stringent international power quality standards and is certified for IEC 61000-4-30 Class A Ed. 3 reporting of power quality conditions.
- The Nexus® 1500+ meter supports automatic generation of customized EN 50160 reports to meet specific jurisdictional requirements.

- Harmonic magnitudes and phase angles in real time are resolved to the 127th order.
- Obtain THD, TDD, and K-Factor.
- Conduct power quality analysis at the high end of the harmonic magnitude spectrum.

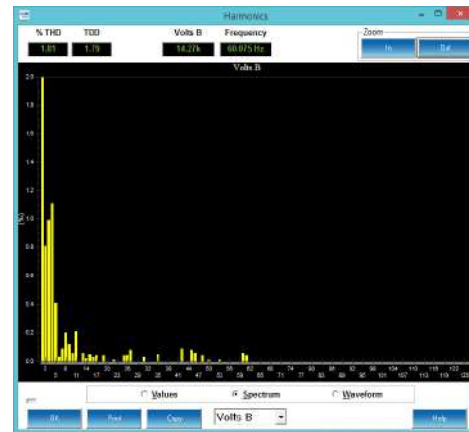

IEC 61000-4-15 Class A Flicker Meter

- Flicker compliant with the IEC 61000-4-15 Class A standard.
- Flicker measurement operates on both 220 V/50 Hz and 120 V/60 Hz throughout standard test points.

Subcycle 50 MHz Transient Recorder (V3 Option)

Transients can alter computer data, destroy electronic circuitry, and damage electrical equipment. The Nexus® 1500+ meter captures these subcycle transient events for analysis.

- Record subcycle transients at 50 MHz resolution.
- Monitor switching noise from capacitors, static transfer switches, SCRs, and other devices that negatively impact power quality.

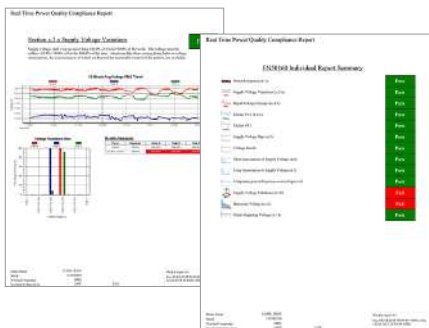

Easy-to-Understand Reports Display PQ Compliance

IEC 61000-4-7 Class A Harmonic and Interharmonic Analysis

- View harmonic magnitudes to the 511th order for each voltage and current channel.

This feature is essential for critical applications, such as hospitals, wafer-fabs plants, data centers, and other applications that are susceptible to the damaging effects of transients.

Independent ITIC/CBEMA Log Plotting

- View a summary of surges, sags, and average duration in the independent ITIC/CBEMA log.
- SEMI F47 graphing for power quality compliance in the semi-conductor industry is also available.

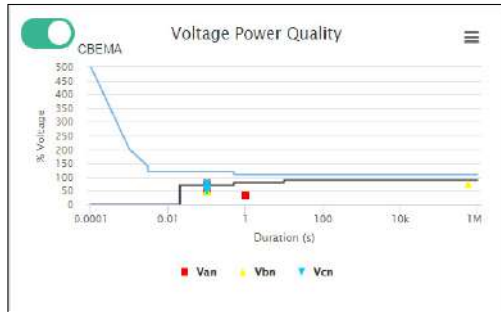

16-bit Waveform and Fault Recorder

- Record up to 1024 samples per cycle at 16-bit resolution.
- Capture a transient at over 800,000 samples per cycle or at 50 MHz sampling speed.
- Voltage and current recording has pre- and post-event analysis.
- Fault recording offers eight times full scale capture capability.
- Both hardware and software triggers are available.
- Directional disturbance analysis.
- Harmonic direction analysis.

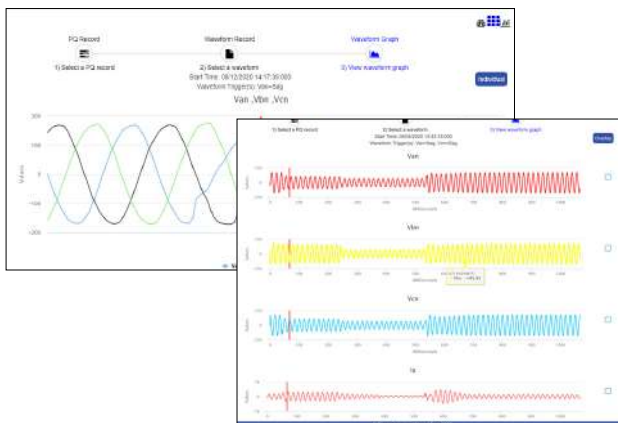

Record and Analyze Waveform Fault and Transient Data

Compatible Waveform Formats

You can use CommunicatorPQA® software to receive the meter's waveform data via COMTRADE and PQDIF compatible formats. This allows the waveform PQ and fault records to be read by most third-party waveform analysis software.

Phasor Analysis

Analyze efficiency and system integrity using phase angle analysis for voltage and current channels.

Set Limit Control

Use the meter's multi-level programming logic to configure setpoints for control. Applications include:

- Capacitor control.
- Load shedding.
- Automatic transfer schemes.
- Transformer monitoring and control.
- Redundant protection (not designed for primary over-current protection).
- Many other control functions.

Alarm Notification

Receive alarm emails or trip internal relay circuits to alert for out-of-limit conditions. Relay outputs can also be used for control applications.

High-speed Voltage Reliability Measurements

- Real time single cycle RMS measurements.
- Customizable high-speed readings – can be set from 2 to 20 cycles RMS.

High-speed Status Input Triggers

- Trigger waveforms to record on a status change event.
- Status changes and waveform recordings are timestamped to a 100 microsecond resolution.
- Time breakers and relays with inputs and waveforms that can be displayed together.

On Board Phasor Measurement Unit (PMU) to Improve Power System Stability

A PMU device measures phasor (magnitude and phase angle of voltage and current) and related data from a specific location on the electrical grid. The measurement is synchronized to a common time source. The time-synchronized estimated phasor is called a synchrophasor. Multiple PMUs transmit the synchrophasors and related data to a phasor data concentrator (PDC), which aggregates and time-aligns the data for real time and post analysis. The Nexus® 1500+ meter acts as a PMU, meeting the IEEE C37.118.1-2011/.1a-2014 standard.

Synchrophasor Benefits

- Instantaneous voltage, current, and frequency at specific locations on the grid provide wide-area situational awareness for system operators.
- Determination of stress points of the transmission system.
- Detection and aid in restoring an islanded section of the grid after a storm or major outage disturbance.
- Visualization of PMU data for system operations, to be incorporated into an Energy Management System (EMS).

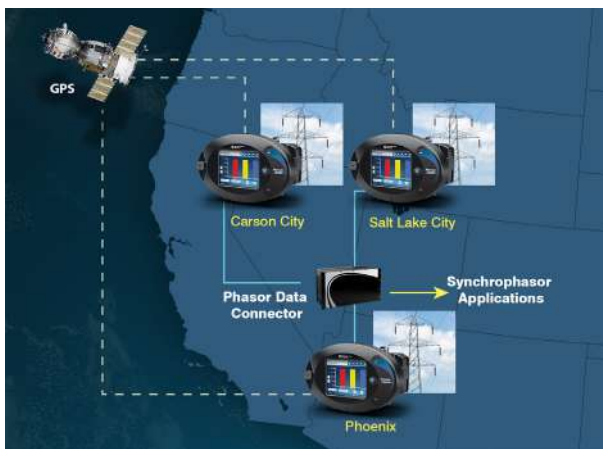

Nexus® 1500+ Synchrophasor Features

- Supports both P and M classes.
- Time sync standard: IRIG-B or IEEE 1588 PTPv2.
- Calculates individual voltage/current phasors, symmetrical components' phasors, frequency, rate of change of frequency, the meter's high-speed digital inputs, analog fundamental power, and displacement power factor.
- Data frame rates: 50 Hz - 10/25/50 frames per second; 60 Hz - 10/12/15/20/30/60 frames per second.
- Data format: configurable float or integer, polar or rectangular.
- Up to two simultaneous clients.
- Supports Ethernet or Fiber over Ethernet communication.

Resilient Cyber Security™

Protect your meter from unwanted intrusions with Resilient Cyber Security™, which provides industry-leading protection against tampering and hacking.

- Digital firmware signature with 512-bit encryption keys to ensure firmware integrity.
- 128-bit AES encrypted communication of sensitive data, such as passwords, usernames, roles, and rights.
- 24 character complex passwords with password expiration.
- Eliminate brute force attacks with password fail timeouts.
- Customizable role-based authorization with eight configurable roles.
- Physical seals and sealing switches, requiring physical access, make remote tampering impossible.
- Security lockout prevents security from being disabled.

Multiport Communication

The Nexus® 1500+ meter meets almost every need for data transmission with its six simultaneous communication ports and multiple protocols.

- Two optional RS485 ports that support Modbus and/or DNP3 Level 2 Plus.
- USB front panel port.
- ANSI optical front panel port.
- Two Ethernet ports.
- Optional Fiber or RJ45 media on one Ethernet port.

Ethernet Communication Port Capabilities

Two Ethernet ports provide multiple simultaneous communication sessions.

- Each port has separate MAC and IP addresses.
- Modbus TCP/IP, DNP3, and IEC 61850 communication.
- GOOSE messaging protocol supported for IEC 61850.
- Up to 32 Modbus TCP/IP sockets per Ethernet port.
- Highly secure port control.
- SMTP email to client on alarm.
- Precise time synchronization via SNTP time sync protocol.
- IEEE 1588 PTPv2 for critical time sync applications, e.g., synchrophasor systems.
- IEEE C37.118.1-2011/.1a-2014 PMU communication.
- File transfer protocol supports high-speed file data transfer.

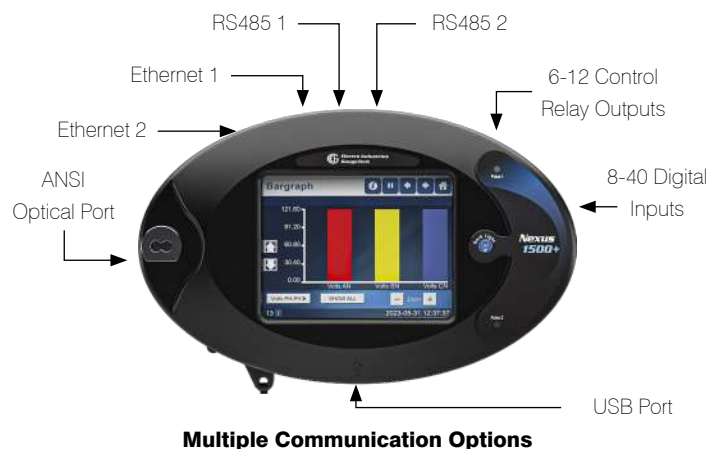

Industry-Leading DNP3 Level 2 Plus

- Up to 136 measurements (64 Binary Inputs, 8 Binary Counters, 64 Analog Inputs) can be mapped to DNP static points.
- Up to 16 relays and 8 resets can be controlled through DNP.
- Report-by-exception processing (DNP Events) deadbands with unsolicited response for serial communication is supported.
- 250 events in four event types (Binary Input Change, Frozen Counter, Counter Change, and Analog Change) are available.

SNMP Protocol

SNMP protocol V1 and V2 is supported.

- 40+ measurements supported.
- Traps for limits, input change, and power quality.
- Cold start trap and authentication failure supported.
- Perfect for data centers and other managed device networks.

Eight Built-in Digital High-speed Status Inputs

- Inputs automatically sense whether the circuit is externally wetted.
- If externally wetted, input up to 150 V DC is accepted.
- If internally wetted, the meter supplies the necessary voltage for the control application.

VAUX Input

- Neutral to ground or aux voltage readings are available.
- Useful for synchronizing schemes, for example, obtaining the frequency, magnitude, and phase angle on both sides of a switch or between generator and bus voltage.

Optional Internal I/O

Provides up to 32 additional points of I/O, expanding the meter's built-in I/O capability.

V-Switch™ Key Upgrades

Upgrade the meter's functionality even after installation using V-Switch™ virtual keys. This means you can purchase what you need now and then upgrade whenever you need the additional features. The table below shows the available V-Switch™ keys.

Features	V-Switch Key™					
	V1	V2	V3	V4	V5	V6
Measurements	✓	✓	✓	✓	✓	✓
Basic Measurement	✓	✓	✓	✓	✓	✓
Memory	512 MB	1 GB	4 GB	512 MB	1 GB	4 GB
Sampling Speed	512	1024	1024	512	1024	1024
50 MHz Transients			*✓			*✓
IEC 61000-4-30 Class A Edition 3	✓	✓	✓	✓	✓	✓
IEC 61850 Server		✓	✓		✓	✓
IEC 61850 GOOSE		✓	✓		✓	✓
Resilient Cyber Security™				✓	✓	✓
Synchrophasor PMU				✓	✓	✓

* Transient sampling rate up to 800k per cycle.

Substation Automation - IEC 61850

V-Switch™ key levels V2, V3, V5, and V6 offer an embedded IEC 61850 Protocol server for seamless integration with substation automation applications. Features of the Nexus® 1500+ meter's IEC 61850 implementation include:

- Up to six simultaneous MMS clients.
- Either Ethernet port can be configured for IEC 61850 (only one port at a time can run IEC 61850).
- GOOSE publisher/subscriber functionality support.
- Buffered and unbuffered reports for the following triggers: general meter interrogation, for example, the report is generated in response to a query; meter integrity, for example, the report is generated according to a programmed interval; and data change, for example, the report is generated due to a change in the contents of a dataset.
- File transfer is supported.
- Embedded Web Protocol server support for IEC 61850 CID file uploading, IEC 61850 Protocol server status, and for displaying incoming and outgoing GOOSE messages.
- Flicker, harmonics, digital inputs/outputs, limit state, voltage, current, energy, and other data, are mapped with multiple, pre-configured logical nodes.
- Waveform capture can be triggered by status input data inside GOOSE messages: the user can program up to 16 status inputs that will trigger a waveform capture when the information is received via a GOOSE message. The status inputs include digital inputs, limit states, and any other status input supported by the meter.

Unique GOOSE Cross Trigger for Distributed Fault Recording

- Provides system wide distribution fault analysis of an event.
- Timing better than 200 microseconds is typical.
- Many different circuits can be viewed after an event occurs.

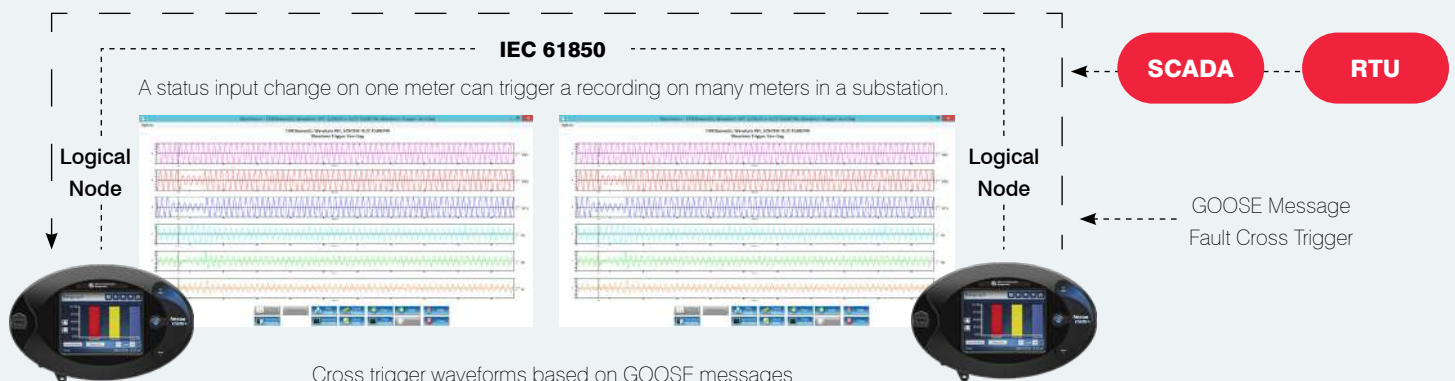

Internal I/O

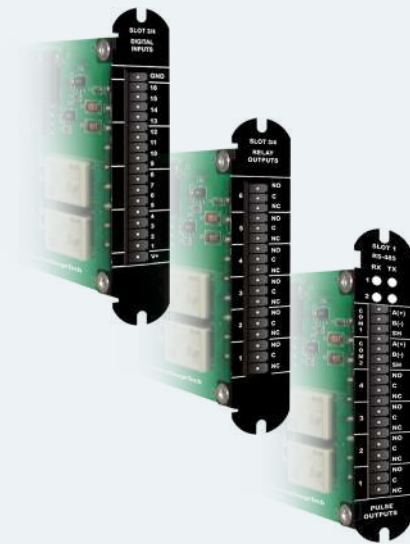

Pulse Outputs

- **485P:** Dual RS485/Pulse Output Card.
- 4 solid state KYZ pulses.
- Pulse width: 5 ms.
- Two RS485 ports.
- UL Rated to 60 V DC.

Relay Outputs

- **6RO1:** 6 Relay Outputs Card.
- 5 A, 250 V AC / 30 V DC.
- Form C (Latching).

Digital Status Inputs

- **16DI1:** 16 Status Inputs Card.
- Used for alarm detection or pulse accumulation.
- Up to 150 V DC wetted or non-wetted (24 V DC provided internally).

Note: See the chart on page 12 for I/O ordering information.

External I/O

Analog Outputs

- **1mAON4 / 1mAON8:** 4 or 8 analog outputs, 0-1 mA, self-powered, scalable, bidirectional.
- **20mAON4 / 20mAON8:** 4 or 8 analog outputs, 4-20 mA, self-powered, scalable.
- Wiring: Common mode.
- Accuracy: 0.1% of full scale.
- Calibration: Self-calibrating.
- Scaling: Programmable.
- Ordering: Up to 4 analog output modules.

Analog Inputs

- **8AI1:** 8 analog inputs, 0 ± 1 mA.
- **8AI2:** 8 analog inputs, 0 ± 20 mA.
- **8AI3:** 8 analog inputs, 0 ± 5 V DC.
- **8AI4:** 8 analog inputs, 0 ± 20 V DC.
- Wiring: Common mode.

- Accuracy: 0.25% of full scale.
- Scaling: Programmable.
- Ordering: Up to 4 analog input modules.

Digital Dry Contact Relay Outputs

- **4RO1:** 4 relay outputs, 5 A, 250 V AC / 30 V DC, Form C (Latching).
- Ordering: 1 module, in addition to internal modules.

Digital Solid State Pulse Outputs

- **4PO1:** 4 solid state pulse outputs, Form A or C KYZ pulses.
- Maximum Pulse Speed: 20 pulses per second.
- Ordering: Up to 4 digital solid state output modules.

I/O Module Accessories (Required)

- **PSIO:** Power supply required when using an external I/O module. The Nexus® 1500+ meter does not have internal power for external I/O modules.
- **MBIO:** Mounting bracket for external I/O modules. Must be ordered with external I/O module.



Modular Expandable External I/O Modules.

Vibrant LCD Touchscreen Display

The Nexus® 1500+ meter uses a bright, high-temperature-rated color LCD touchscreen display. Features include:

- Vertical or horizontal presentation to support different installation options.
- View real time oscilloscope waveforms.
- View harmonic spectrum analysis.
- View real time trending.
- Test mode.
- Four quadrant energy and time of use.
- View alarm status.
- Supports multiple languages - English, Spanish, Hebrew, Chinese, Portuguese, French, Polish.
- Security status and settings.
- Over 60 screens.



Wiring Diagrams

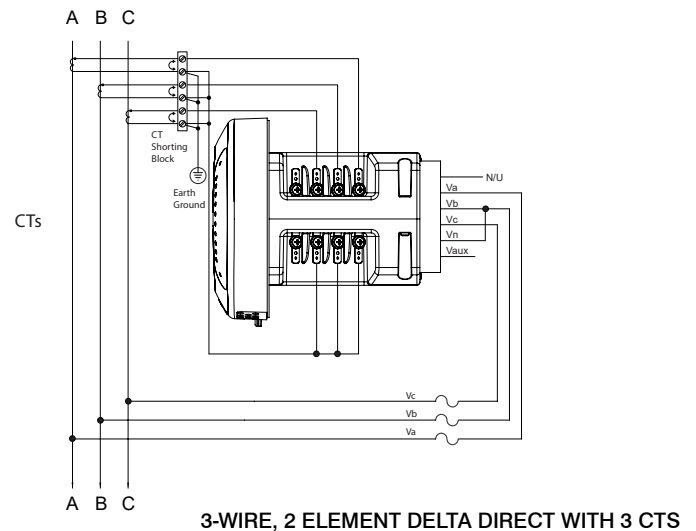
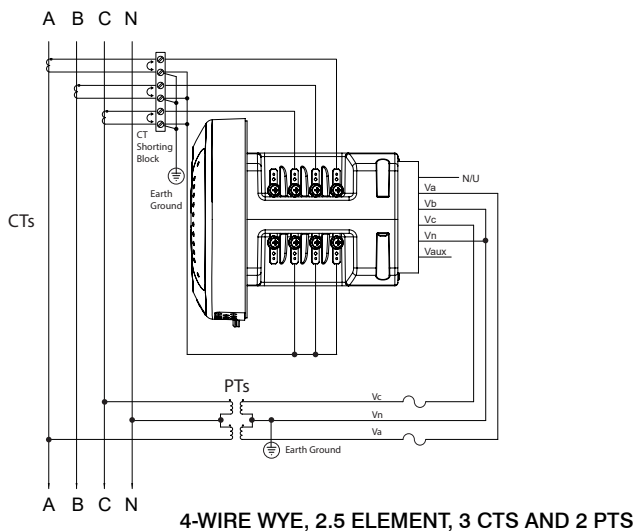
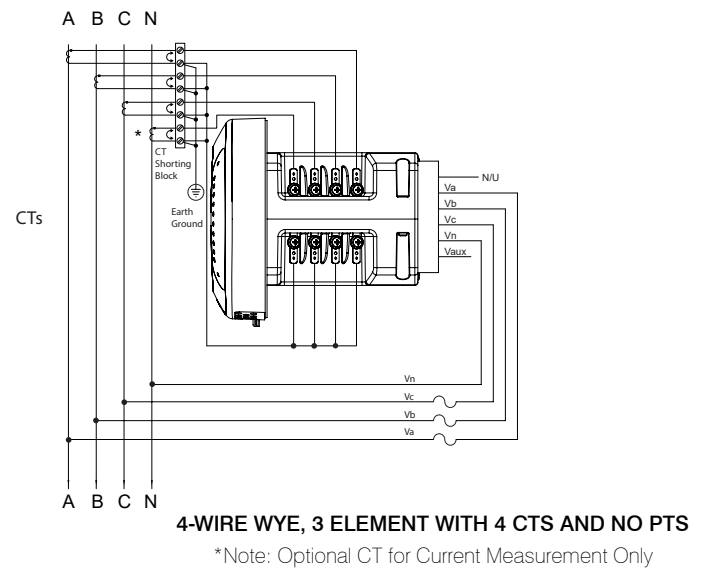
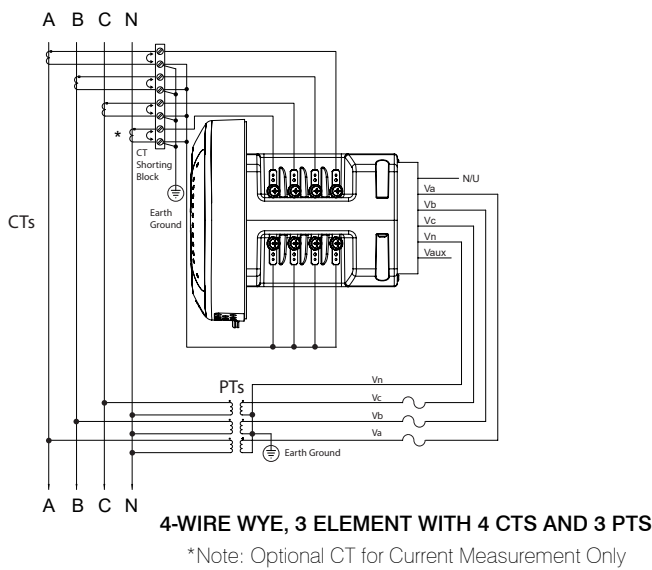

Dimensional Drawings

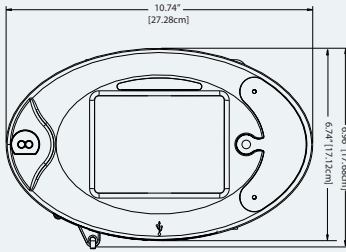

FRONT

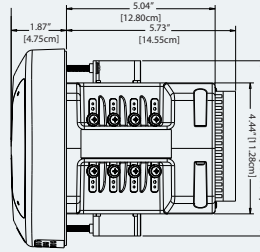

SIDE

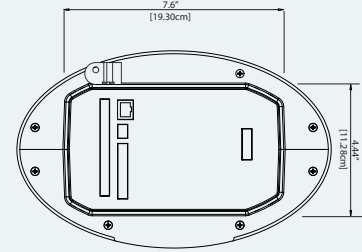

BACK

Specifications

Voltage Input Range

- (5-347) V AC, Line to Neutral
- (10-600) V AC, Line to Line

Voltage Input Withstand Capability

- Voltage Inputs isolated to 2500 V AC

Current Input Range

- Programmable to any CT ratio
- Class 2: 1 A nominal CT secondary, with 2 times overrange
- Class 2: fault current recording to ± 16 A peak
- Class 20: 5 A nominal CT secondary, with 4 times overrange
- Class 20: fault current recording to ± 80 A peak

Current Input Withstand Capability (at 23 °C)

- 100 A for 10 seconds, 300 A for 3 seconds, 500 A for 1 second

Burden

- Voltage Inputs: 0.072 VA/phase max at 600 volts, 0.003 VA/phase max at 120 volts
- Current Inputs: 0.008 VA per phase max at 20 A

Isolation

- All inputs to outputs are isolated to 2500 V AC

Environmental

- Operating temperature: (-20 to +70) °C
- Storage temperature: (-30 to +80) °C
- Humidity: Up to 95% RH non-condensing
- Protection Class: IP30

Sensing Method

- Up to 1024 samples per cycle (programmable)

- 16-bit A/D resolution – multiple converters
- Constant Calibration™ technology
- True RMS
- Transients measured at 800,000 samples per cycle

Accuracy Rating

- Energy measurement accuracy at 0.06%
- Full accuracy specifications available in Nexus® 1500+ meter User Manual
- Time clock: 3.5 ppm for (-40 to +85) °C - less than 10 seconds drift per month on crystal sync; 2.0 ppm typical from (0 to +40) °C - less than 6 seconds per month drift

Update Time

- 1 second - Revenue accurate readings
- 1 cycle high-speed frequency readings
- Customizable high-speed readings - from 2 to 20 cycles RMS

Control Power Requirements

- D2 Option: UL Rated (100-240) V DC, (90-264) V AC @50/60 Hz/17 W Max
- 115AC Option: UL Rated (100-240) V AC @50/60 Hz/17 W Max
- D Option: UL Rated (18-60) V DC (24-48 V DC Systems) /25 VA Max

Frequency Range

- (42.5-69.9) Hz

Communication

- Programmable parity and stop bits
- Communication protocols: Modbus TCP/IP, ASCII/RTU; DNP3; IEC 61850 (V2, V3, V5, V6), SNMP
- ANSI optical port
- USB 1.1/2.0 Virtual COM port

- RJ45 10/100BaseT Ethernet port
- Optional 2nd Ethernet port - RJ45 or Fiber Optic
- 2 RS485 ports (optional)

Shipping

- Total shipping weight: approx. 6.5 lbs (2.9 kgs)
- Shipping container dimensions: 16" x 15.5" x 11.5" (40.64 cm x 39.37 cm x 29.21 cm)

Compliance

- ANSI C12.20 2010 - 0.1 Accuracy Class and C12.1 2008; 0.2 CL (MET Labs Certified)*
- ANSI C62.41 (Burst)
- FCC, Part 15, Subpart B, Class A (Radiated and Conducted Emissions)*
- IEC 62053-22 Accuracy, 0.2S (KEMA Labs Certified)*
- IEC 62053-23 Ed. 1
- CE (EN/IEC 61326-1 & EN/IEC 61000-3-2 & EN/IEC 61000-3-3) Certified*
 - IEC 61000-4-2 Ed. 2 2008 (Electrostatic Discharge)*
 - IEC 61000-4-3 Ed. 3.2 2010 (Radiated EM Immunity)*
 - IEC/EN 61000-4-4 Ed.3 2012, Class B (EFT)*
 - IEC/EN 61000-4-5, Class B (Surge Immunity)*
 - IEC 61000-4-6 Ed. 3 2008 (Conducted Immunity)*
 - IEC 61000-4-8 Ed. 2 2009 (Magnetic Immunity)*
 - IEC 61000-4-11 Ed. 2 2004 (Voltage Variations Immunity)*
- IEC 61000-4-30 Class A Ed.3 Certified*
 - IEC 61000-2-4 (Compatibility Levels)*
 - IEC 62586-2 Ed. 2 2017 (PQ Measurement in Power Supply Systems)*
 - IEC 61000-4-7 Ed. 2 2002

(Harmonics)*

- IEC 61000-4-15 Ed. 2 2010 (Flicker Meter)*
- IEC 61000-6-2 2005 (Immunity for Industrial Environments)
- IEC 61000-6-4 2006 (Emissions Standards for Industrial Environments)
- IEC 61850 Level A, Ed. 2 Certified*
- IEEE C37.118.1-2011/1a-2014
- CISPR11 Ed. 5.1 (Conducted Emissions)*
- CISPR22 Class A
 - IEC 62052-11 2003- General Requirements
- EU Directive 2011/65/EU (RoHS Directive)
- REACH Compliant
- Certified to UL/IEC 61010-1 and CSAC22.2 No. 61010-1, UL File: E250818

External I/O Modules

- 1mAON4: 4 Analog Outputs, 0 \pm 1 mA
- 1mAON8: 8 Analog Outputs, 0 \pm 1 mA
- 20mAON4: 4 Analog Outputs, 4-20 mA
- 20mAON8: 8 Analog Outputs, 4-20 mA
- 8AI1: 8 Analog Inputs, 0 \pm 1 mA
- 8AI2: 8 Analog Inputs, 0 \pm 20 mA
- 8AI3: 8 Analog Inputs, 0 \pm 5 V DC
- 8AI4: 8 Analog Inputs, 0 \pm 10 V DC
- 4RO1: 4 Relay Outputs
- 4PO1: 4 Solid State Pulse Outputs
- PSIO: Power Supply for I/O modules**
- MBIO: I/O mounting bracket**

Note: Please see product User Manual for comprehensive specifications.

*Third party lab tested

**Must be ordered with external I/O modules

Ordering Information - All fields must be filled in to create a valid part number.

	Nexus® Base Meter	Control Power	Frequency Range	Current Class	V-Switch™ Pack	Communication Slot 1	I/O Slot 2	I/O Slot 3	I/O Slot 4
Option Numbers:	-	-	-	-	-	-	-	-	-
Example:	Nexus1500+	D2	60	20	V2	485P	NTRJ	6RO1	6RO1
	Nexus® 1500+ (Meter)	115AC (100-240) V AC @50/60 Hz	60 60 Hz System	20 5 A Nominal CT Secondary	V1 Standard Nexus® 1500+ Meter 512 MB Memory / 512 s/c	X No Option	X No Option	X No Option	X No Option
		D2 (100-240) V DC, (90-264) V AC @ 50/60 Hz	50 50 Hz System	2 1 A Nominal CT Secondary	V2 V1 with 1 GB Memory / 1024 s/c IEC 61850	485P 2 RS485 and 4 Pulse Outputs	NTRJ Second RJ45 Network Card	6RO1 6 Relay Outputs	6RO1 6 Relay Outputs
		D (18-60) V DC			V3 V2 with 4 GB Memory / 50 MHz Transient Recording		NTRJ Second Fiber Network Card (ST terminated)	16DI1 16 Status Inputs	16DI1 16 Status Inputs
					V4 V1 + Synchrophasor PMU and Resilient Cyber Security™				
					V5 V2 + Synchrophasor PMU and Resilient Cyber Security™				
					V6 V3 + Synchrophasor PMU and Resilient Cyber Security™				

Additional Options

Software

COMPQA6P1Y	CommunicatorPQA® 6 Configuration Software - Single-Computer License (One Site)	ENERGYPQA-1Year	AI Driven Energy Management System
-------------------	--	------------------------	------------------------------------

I/O Module Options - *Must be ordered with an external I/O Module.

1mAON4	4 Analog Outputs, 0±1 mA	8AI1	8 Analog Inputs, 0±1 mA	4RO1	4 Relay Outputs
1mAON8	8 Analog Outputs, 0±1 mA	8AI2	8 Analog Inputs, 0±20 mA	4PO1	4 Solid State Pulse Outputs
20mAON4	4 Analog Outputs, 4-20 mA	8AI3	8 Analog Inputs, 0±5 VDC	PSIO*	Power Supply for External I/O Module
20mAON8	8 Analog Outputs, 4-20 mA	8AI4	8 Analog Inputs, 0±10 VDC	MBIO*	I/O Mounting Bracket

1800 Shames Drive
Westbury, NY, 11590

1-877-EIMETER
(1-877-346-3837)

Tel: 516-334-0870
Fax: 516-338-4741

Email: EIG_sales@hubbell.com
Website: www.electroind.com

