

# Nexus<sup>®</sup> 1450

**CYBER SECURE POWER  
QUALITY METER WITH  
MULTIPOINT COMMUNICATION**



Nexus<sup>®</sup> 1450 Meter

**P70N Color Touchscreen  
LCD Display**

## Metering and Communication

- 0.06% Energy Accuracy; Meets ANSI C12.20 0.1 Accuracy Class
- Multi-Gain™ Sensing Provides Highly Accurate Measurements Over a Wide Dynamic Range
- Advanced Web Server with Waveform Analysis Tools
- Resilient Cyber Security™ Protects Your Power System Data
- 6 Available Communication Ports, with Modbus and DNP3 Level 2 Protocols and RTU Master Capability
- Two Independent Ethernet Ports, with Unique IP Addressing, Port Control for Security, and Encrypted Email on Alarm
- IEC 61850 Protocol with GOOSE Messaging and Distributed Fault Recording
- Wideband Frequency (20-500) Hz Support

## Advanced Power Quality Analysis

- IEC 61000-4-30 Class A Edition 3 Power Quality Measurements
- IEC 61000-4-15 Class A Flicker Measurements
- IEC 61000-4-7 Class A Harmonic Measurements
- EN 50160 Power Quality Reports
- Up to 1024 Samples per Cycle Measurements
- New CORE™ Onboard Database Logging Architecture
- Easy Installation of Transducer and Separate Display
- Direct Physical Retrofit to Nexus<sup>®</sup> 125X Series Meter/Transducer with Greater Functionality
- Separate 3 Line LED Displays and New Color Touchscreen LCD Display



# Introduction

Electro Industries' Nexus® 1450 meter is a powerful power quality meter that provides accurate electrical energy measurements. It offers advanced capabilities for power quality analysis and determining electrical power reliability. The meter is a transducer base with a separate display. The transducer base retrofits to existing Electro Industries' Nexus® 1250 and 1252 meters. The Nexus® 1450 meter is ideal for existing switchboard panels since it can be installed without cutting panel doors. The separate display mounts into existing analog meter knockouts.

# Multi-Gain™ Sensing Provides Superior Accuracy

The Nexus® 1450 meter utilizes EIG's latest measurement-sensing technology - Multi-Gain™ metrology. Multi-Gain™ technology uses two sensors on the current inputs - a high gain sensor and a lower gain sensor. Each sensor simultaneously measures the current signal coming from the external current transformers. The meter's intelligent processing looks at the signal level and determines the optimal sensing circuit for the highest accuracy measurement. With this technique, the meter has 0.06% accuracy throughout an extended measurement range, which is a defining trait of Nexus® Series meters.

The meter's standard pickup range starts as low as 1 mA and high accuracy is attained at 25 mA. With Multi-Gain™ metrology, the same meter can be used on both 5 A secondary and 1 A secondary CTs. The meter should maintain high accuracy measurement throughout its installed life.

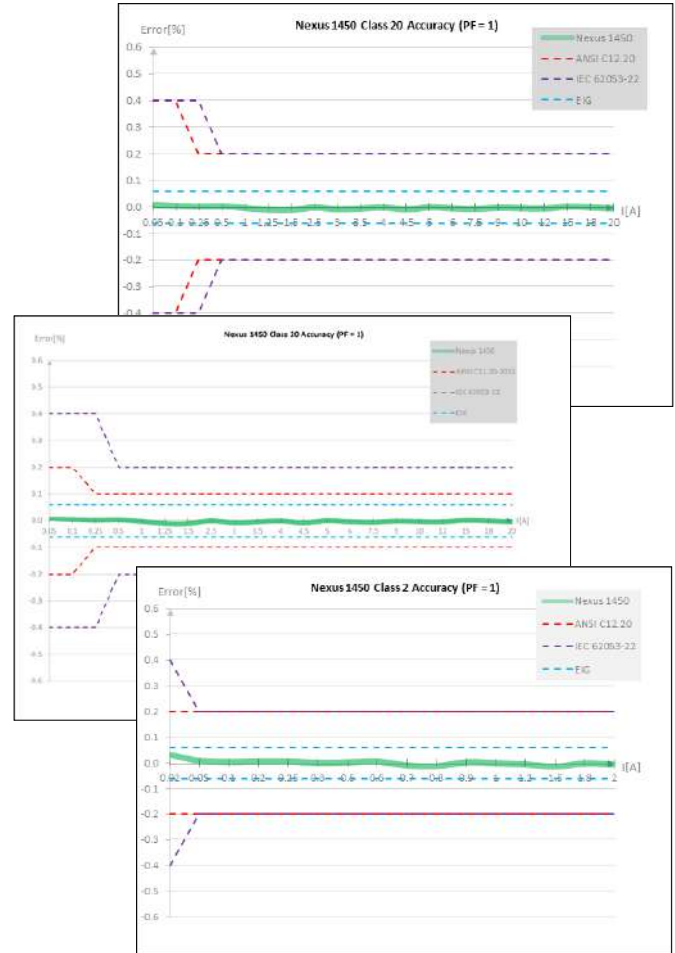

Typical Accuracy Charts



Four High Gain Sensors

Four Low Gain Sensors

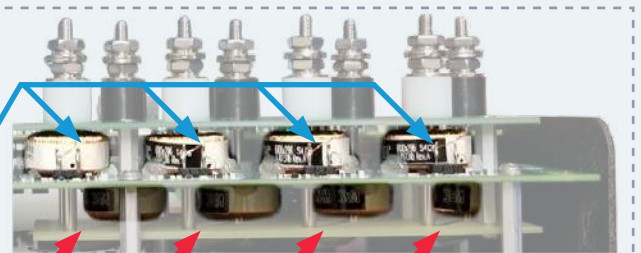

Multi-Gain™ Metrology Gives the Nexus® 1450 Meter Highly Repeatable and Stable Measurements Throughout its Measurement Range.

# Meter Accuracy

Features	
Voltage L-N	0.04% of reading
Voltage L-L	0.04% of reading
Current	0.04% of reading
Neutral Current	0.1%
Frequency*	0.001 Hz
Watts	0.06% of reading
Watt-hour**	0.06% of reading
VAR	0.15% of reading
VARh	0.15% of reading
VA	0.06% of reading
Power Factor	0.15% of reading
THD	2.5% of reading

\* For 50/60 Hz measurement. The Nexus® 1450 meter also supports wideband accuracy for (20 - 500) Hz applications; full accuracy specifications are given in the Nexus® 1450 Meter User Manual.

\*\* (0.025 to 20) A at PF=1

## Precision Crystal Time Reference

The Nexus® 1450 meter's internal clock crystal is accurate to 20 ppm at 23 °C. It can be used if other time sync methods are not enabled.

The meter offers additional time sync methods:

- Line frequency sync.
- IRIG-B time sync.
- DNP3 time sync.
- SNTP time sync.

# Advanced Energy Meter for Primary Loads

Use the Nexus® 1450 meter for any critical metering application. In addition to highly accurate energy measurement, the meter features:

- Full four quadrant metering.
- Max/min recording with timestamp.

- Extensive logging, with eight logs of programmable historical profiles.
- Built-in CORE™ log provides pre-configured, automatic logging of most metering parameters.
- Transformer and line loss compensation for both iron and copper and total substation losses.
- Coincidental readings, e.g., PF or VARs at time of peak demand.
- Load aggregation/universal metering; aggregate or accumulate different loads using pulse inputs. Utility commodities such as gas and water can also be accumulated.

## Perpetual Time of Use for Complex Metering

Set up multiple tariffs to meet any contractual obligation with the Nexus® 1450 meter's perpetual time of use (TOU) calendar. You program the calendar only one time, unless your requirements change. Use your TOU calendar for any energy parameter, stored data from pulses, or RTU Master readings. TOU features include:

- Up to four customizable seasons.
- Flexible billing periods/rates/holidays/schedules.
- Cumulative and continuous cumulative demand.

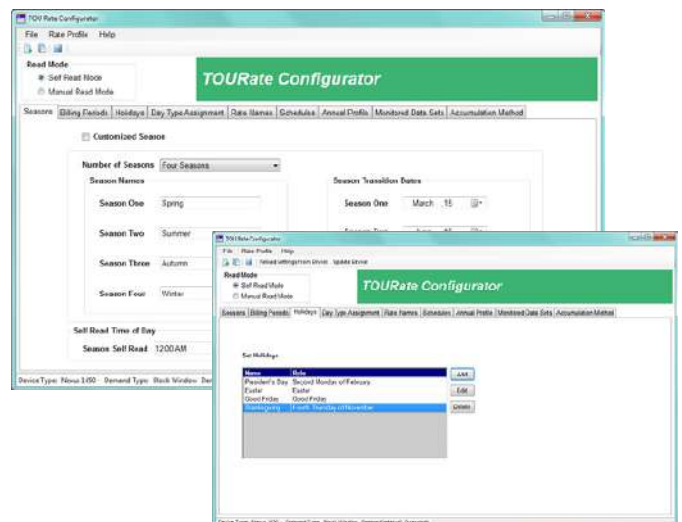

Easily Configure Almost any TOU Usage Profile

# Datalogging and Internal Storage

The Nexus® 1450 meter provides advanced capabilities for storing measured values over time, for trending and analysis. The meter has up to 4 GB of memory with up to 1.2 GB allocated exclusively to logging and user storage. All logs use a FIFO buffer and roll over when full. The following logs are available.

## Trending Logs

- **CORE™ Log** - the meter uniquely uses an internal SQL database that automatically logs 172 metering parameters. This ensures that most parameters are already logged, providing data without a complex configuration process.
- **Historical Logs** - the meter supports eight configurable historical trending logs of 64 data channels per log.

## System Events Security Log

This anti-tampering log records all events in the meter with an associated timestamp. The unit records:

- Resets.
- Meter programming changes.
- Time changes.
- Power up/down.
- Change of V-Switch™ key.
- TOU profile changes.
- Password and security events.
- Change of firmware.

## Power Quality Log

This log captures power quality events, such as surges, sags, and transients, and lets you view and analyze the data through power quality graphs, such as the ITIC CBEMA Curve and SEMI F47 standards.



## Input Status Change Log

This log supplies information on the state of the meter’s eight internal digital inputs.

## Limit Log

The Limit/Alarm log can be set to record on high and low conditions for up to 32 user programmable limits.

## Chart for Memory Logging

Features	V1 - Maximum # of Records	Days	V2 - Maximum # of Records	Days
System Events	16384		32768	
CORE™ Log*	16384	163	32768	327
Log 1**	16384	163	32768	327
Log 2**	16384	163	32768	327
Log 3**	16384	163	32768	327
Log 4**	16384	163	32768	327
Log 5**	16384	163	32768	327
Log 6**	16384	163	32768	327
Log 7**	16384	163	32768	327
Log 8**	16384	163	32768	327
Digital Input	16384		32768	
Limits/Alarms	16384		32768	
Power Quality	16384		32768	
Waveforms***	For 512 samples per cycle, 1 second waveform recording at 60 Hz: 682 records.		For 1024 samples per cycle, 1 second waveform recording at 60 Hz: 341 records.	

\* The CORE™ log automatically records readings for 172 parameters at the logging interval. The default interval is 15 minutes. Days are based on approximately 100 records per day.

\*\* Logs 1 - 8 are user-assignable and allow 64 parameters per log. Days are based on approximately 100 records per day.

\*\*\* The number of waveform records depends on the sampling rate and the length of waveform recording. V1 offers up to 512 samples/cycle recording and V2 offers up to 1024 samples/cycle recording.

# Power Quality Measurements

Critical sensitive equipment and over utilized distribution systems must be monitored for proactive system reliability improvements. Measure power quality indices such as voltage anomalies, harmonics, flicker, imbalances, and many other conditions with the Nexus® 1450 meter. You can then easily quantify your system reliability using this information. Facilitate forensic engineering analysis of harmful events in your power system with the meter's micro-second resolution recording of sag/swell waveform events, including peak and duration of the event.

## Certified to IEC 61000-4-30 Class A Ed. 3

The Nexus® 1450 power quality meter's measurements are third party certified to the most stringent international power quality standards.

## IEC 61000-4-7 Class A Harmonic and Interharmonic Analysis

- View harmonic magnitudes to the 511th order for each voltage and current channel with EIG's LogViewerPQA software.
- Real time harmonic magnitudes and phase angles are resolved to the 127th order.
- Obtain THD, TDD, and K-Factor.
- Conduct power quality analysis at the high end of the harmonic magnitude spectrum.

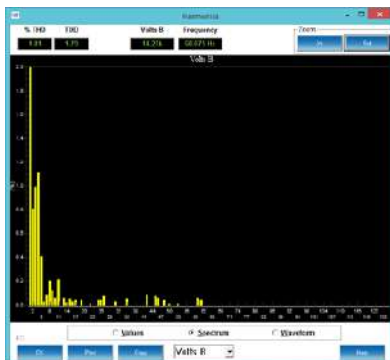

Harmonic Spectrum Analysis

## IEC 61000-4-15 Class A Flicker Meter

- The Nexus® 1450 meter measures flicker in compliance with the IEC 61000-4-15 Class A standard.
- Operates on both 230 V/50 Hz and 120 V/60 Hz.

## Limits/Alarms

Set multiple programmable limits for any measured value and for conditions set up using a Boolean logic tree. The meter records events based on your threshold settings. Trigger control events with limits that can be used with timers and logic. In addition, the Ethernet ports can be programmed to send emails on alarm.

## EN 50160 Power Quality Reports

The meter calculates weekly EN 50160 power quality reports. Determine power system reliability with these reports, which can be easily accessed from the meter's web server.

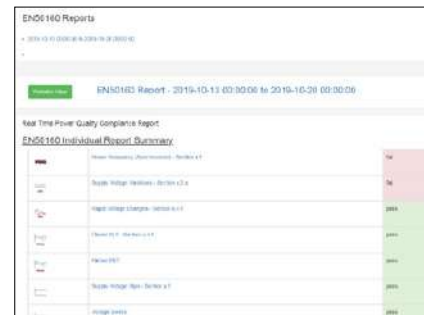

Power Quality Reporting

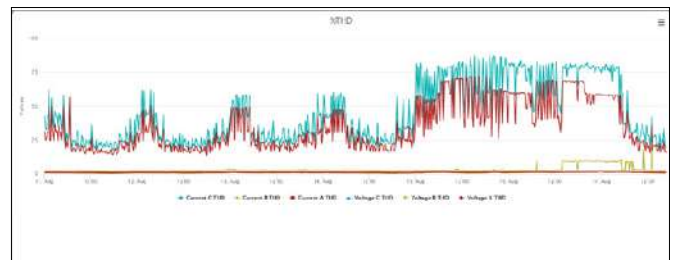

THD Trending

## COMTRADE Support

Download COMTRADE files directly from the meter through web RESTful API access.

## Waveform Recording

The Nexus® 1450 meter records waveforms at a sampling rate of up to 1024 samples/cycle on multiple power quality events, including surges, sags, and transients. 16-bit A/D conversion provides precise waveform resolution. Both voltage and current recording offer pre- and post-event analysis. Fault recording offers eight times full-scale capture capability. Waveform recording for wideband frequencies is also supported. You can program both hardware and software triggers to record a waveform.

View waveforms through either CommunicatorPQA® software, the meter's web browser, or the EnergyPQA.com® cloud-based energy management system. You can also download the waveforms to third party software for analysis. Analyze the waveforms to determine the source of power quality anomalies and then take steps to remedy the situation.

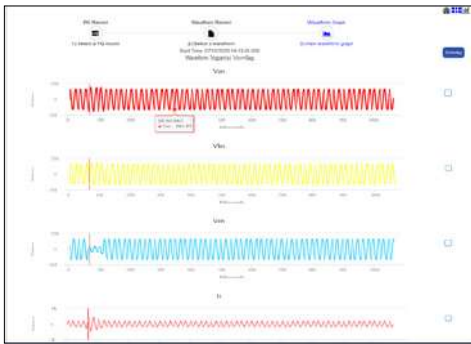

View High-resolution Waveform Events

## Phasor Analysis

View phase angles and symmetrical components for voltage and current with EIG's Log Viewer. This information can help you analyze electrical system problems.

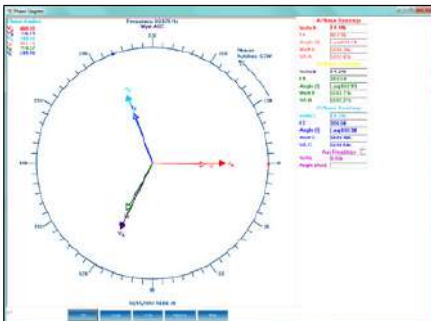

Analyze Power System Phasors

## Resilient Cyber Security™ Protects Meter from Tampering

- Highly secure, 32 complex character passwords with 128-bit AES Encryption.
- Password fail timeouts virtually eliminate brute force hacking.
- An admin and 10 customizable users.
- Four roles with customized user permissions.
- Physical seals and sealing switch prevent remote hacking or tampering.
- Firmware verification and authentication to ensure firmware integrity when updating firmware.

## V-Switch™ Key Technology

The Nexus® 1450 meter has EIG's V-Switch™ key technology that lets you upgrade meter functionality even after installation. This means you can purchase what you need now and then upgrade whenever you need the additional features. V1 has the following features:

- Basic measurements of voltage, current, etc.
- THD and harmonics.
- Time of Use.
- Waveform recording at 512 samples per cycle.
- Flicker, IEC 61850-4-20 Class A Ed. 3.
- EN 50160 reporting.
- CORE™ log.
- Custom historical logs.
- PQ log, Waveform log, Limit log, Digital input log, System Events log.
- 512 MB memory for logging.\*
- Serial communication supporting Modbus and DNP3 Level 2.
- RJ45 and Fiber Ethernet communication supporting Modbus and DNP3 Level 2.

V2 adds the following:

- Waveform sampling rate of 1024 samples/cycle.
- 1200 MB memory for logging.\*
- IEC 61850.

\* The unit has 4000 MB flash memory for longer reliable life. Some of the memory is allocated to wear-leveling and system use.

# Advanced Communication

The meter has six standard communication ports that include four serial ports and two Ethernet-based ports. The Ethernet ports consist of an ST terminated fiber optic port and an RJ45 port. The Nexus® 1450 meter can communicate with many different SCADA or other systems, simultaneously.

## Port Details

- Six standard Com ports.
  - Four serial ports - RS485 (one of the ports is RS485/RS232 selectable); RTU Master capability.
  - Two independent Ethernet ports - RJ45 and Fiber Optic, with separate IP addresses, advanced port control, and encrypted email on alarm. The RJ45 port supports DHCP and IPv6.
- Modbus RTU, Modbus ASCII, Modbus TCP/IP, DNP3 Level 2 communication.
- IEC 61850 protocol server (V2).
- IEC 61850 GOOSE server (V2).
- GOOSE cross trigger for distributed fault recording (V2).
- Ports can communicate simultaneously.
- Ports 3 and 4 can control up to four I/O modules each, acting as an RTU master to slave bus devices.
- Encrypted email on alarm: email on exceeded limit, waveform recording, status change, password tampering, and many other conditions.

# Standard I/O

## 8 Built-in Digital Status Inputs

- Inputs automatically sense whether the circuit is externally wetted.
- If externally wetted, input up to 150 V DC is accepted.
- If internally wetted, the meter supplies the necessary voltage for the control application.
- Inputs can be used as pulse accumulators for counting pulses from other meters.

## VAUX Input

- Supplies neutral to ground or aux voltage readings for synchronizing schemes, for example, obtaining the frequency, magnitude, and phase angle on both sides of a switch or between generator and bus voltage.

## Two Standard Pulse Outputs

- Solid State, form A, 35 Ω max on resistance.
- 120 mA continuous, 350 mA max for 10 ms.
- Peak voltage: 350 V DC.
- Switching rate max: 10/s.
- Support pulse-counting applications.



\* Two standard test pulses for Wh and VARh testing.

The Nexus® 1450 meter is a direct physical retrofit to Nexus® 1250 and 1252 meters.

# Revenue Seal

The Nexus® 1450 meter has a lockable cover for voltage and current inputs, a demand and programming Reset button seal, and two physical meter seal locations. Seals other than demand/programming can be ordered separately.

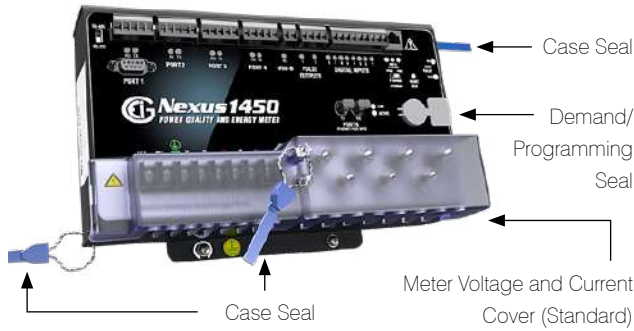

Revenue Seal Diagram

## Optional I/O

### Analog Outputs

- **1mAON4/1mAON8:** 4 or 8 Analog Outputs,  $0 \pm 1$  mA, self-powered, scalable, bidirectional.
- **20mAON4/20mAON8:** 4 or 8 Analog Outputs, 4-20 mA, self-powered, scalable.
- **Wiring:** Common mode.
- **Accuracy:** 0.1% of full scale.
- **Calibration:** Self-calibrating.
- **Scaling:** Programmable.
- **Ordering:** Up to four Analog Output modules.



I/O Modules

### Analog Inputs

- **8AI1:** 8 Analog Inputs,  $0 \pm 1$  mA.
- **8AI2:** 8 Analog Inputs,  $0 \pm 20$  mA.
- **8AI3:** 8 Analog Inputs,  $0 \pm 5$  V DC.
- **8AI4:** 8 Analog Inputs,  $0 \pm 10$  V DC.
- **Wiring:** Common mode.
- **Accuracy:** 0.25% of full scale.
- **Scaling:** Programmable.
- **Ordering:** Up to four Analog Input modules.

### Digital Inputs

- **8DI1:** 8 Digital Status Inputs, Wet/Dry.
- Auto-detect up to 300 V DC
- **Ordering:** Up to four Digital Input modules.

### Digital Dry Contact Relay Outputs

- **4RO1:** 4 Relay Outputs, 5 A, 250 V AC/30 V DC, Form C, Latching.
- **Ordering:** Up to four Digital Dry Contact Relay Output modules.

### Digital Solid State Pulse Outputs

- **4PO1:** 4 Solid State Pulse Outputs, Form A or C KYZ pulses.
- **Maximum Pulse Speed:** 20 pulses per second.
- **Ordering:** Up to four Digital Solid State Pulse Output modules.

### I/O Module Accessories

- **PSIO:** Power supply for up to four additional I/O modules (this accessory may be needed when using three or more displays and/or modules).
- **MBIO:** Mounting bracket for external I/O modules (required with any external I/O module order).

### Optional Displays (displays connect to any RS485 port).

- P40N+ multifunction LED master display supplies visual display of meter readings, has a USB connection for direct data download, and can also be used as a master volt display. The P40N+ display is ideal for analog ANSI meter retrofits.
- Optional slave displays P41N+ (Ampere display) and P43N+ (Power display) can be daisy chained with a P40N+ master.
- P70N color touchscreen display offers multiple pre-configured screens of meter readings and power quality data. It can be mounted in a panel or as a retrofit to an existing ANSI meter cutout using the SMKP70N mounting kit.

# WebView™ Energy Dashboard

## Use the Built-in Energy Dashboard to Analyze Metering Data Without Needing Software

The Nexus® 1450 meter utilizes a unique HTML5-based web server. This new web server acts as an energy dashboard that lets you view real time data. You can also analyze stored historical logs, alarms, and waveform records using the dashboard. The WebView™ Energy Dashboard is built on a responsive architecture, so that it works properly on handheld browser-based devices, such as tablets and phones. Navigate easily through multiple webpage views, getting detailed information on energy usage and power quality:

- Real time voltage and current readings and detailed charts show energy use over time.
- Energy usage, quadrant energy charts, and trending.
- Waveform event records, including zoom and pan.
- Status of digital inputs.
- Phasor diagram.
- Flicker readings, including PST and PLT.
- Symmetrical components.
- Detailed information for accumulators and aggregators.
- Meter information and diagnostic webpages for meter health and status.
- View data directly from the meter's web viewer.



Sample of Watt and VAR Trending over Webpage

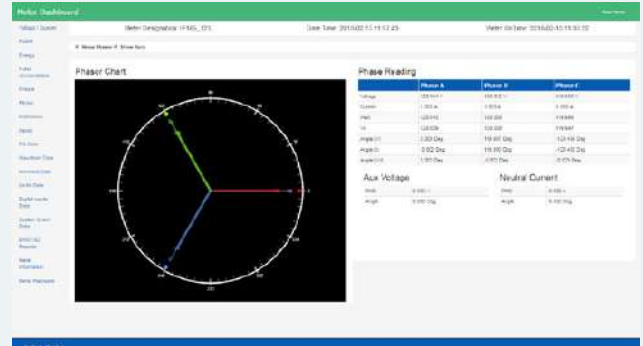

Phasor Screen



Energy Screen

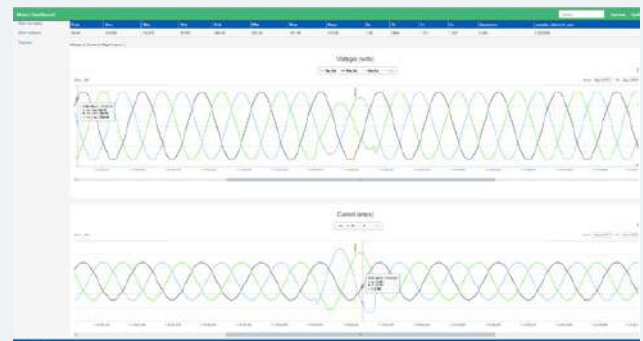

Web-based Waveform Recording Screen

# Nexus<sup>®</sup> 1450 Meter Base Dimensions

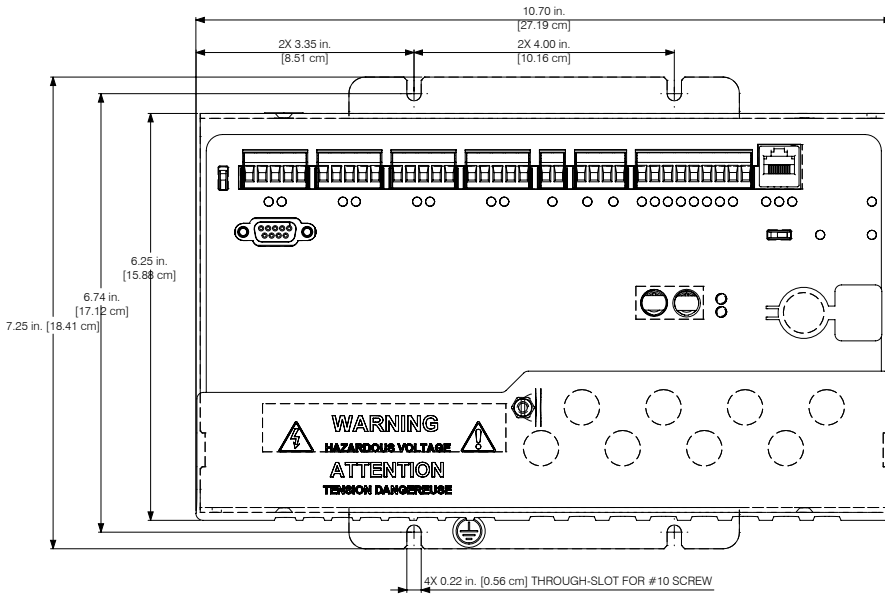

FRONT DIMENSIONS

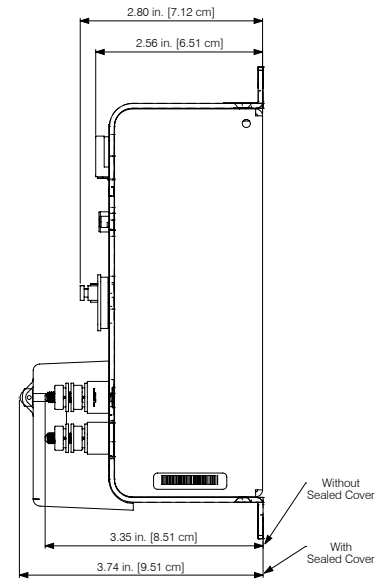

SIDE DIMENSIONS

# Nexus<sup>®</sup> LED/LCD Display Dimensions

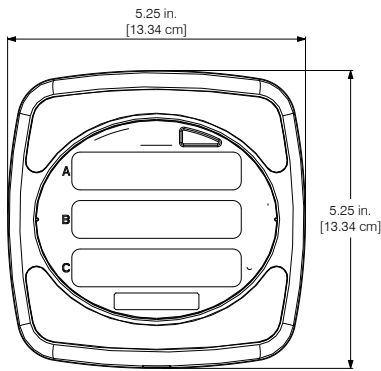

P40N+ FRONT DIMENSIONS

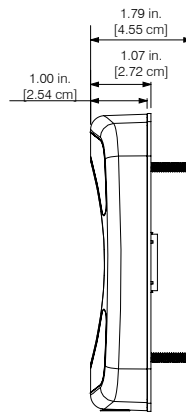

P40N+ SIDE DIMENSIONS

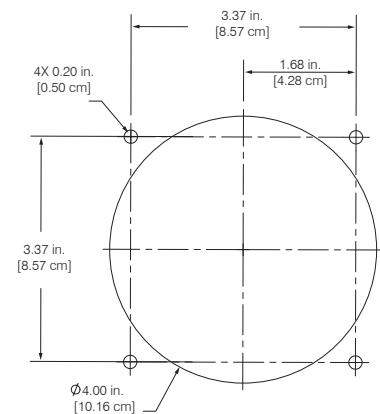

P40N+ MOUNTING OR  
 P70N ANSI MOUNTING KIT - SMK P70N

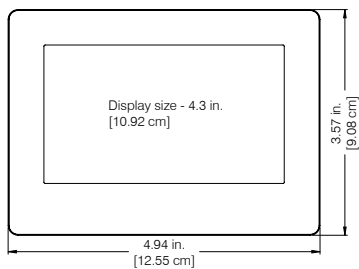

P70N FRONT DIMENSIONS

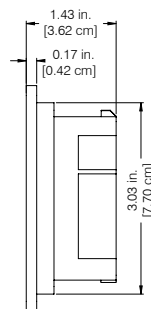

P70N RIGHT DIMENSIONS

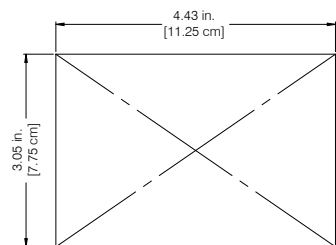

P70N MOUNTING DIMENSIONS

**Note 1:** Mounting and I/O module details are in the *Nexus<sup>®</sup> 1450 Meter User Manual*.  
**Note 2:** P41N+ and P43N+ displays have the same dimensions as the P40N+ display.

# Wiring Diagrams and Specifications

Additional wiring diagrams for the meter are included in the Nexus® 1450 Meter User Manual.

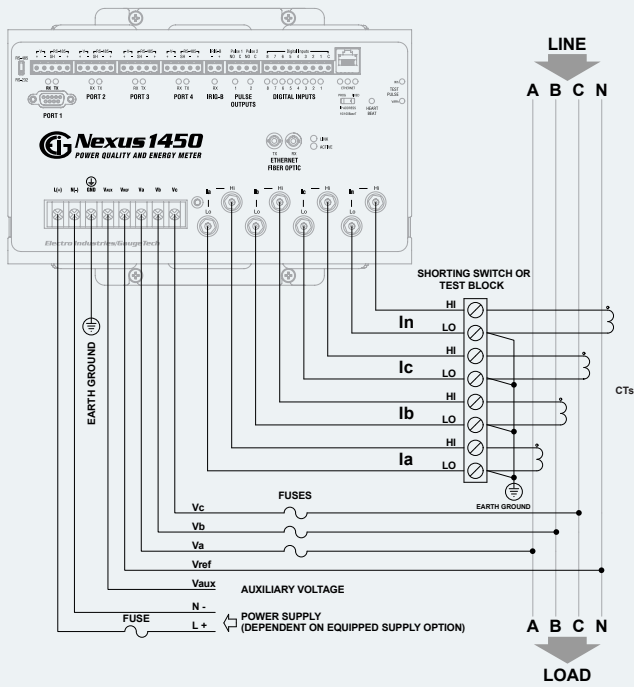

4 WIRE WYE, 3 ELEMENT DIRECT VOLTAGE WITH 4 CTs

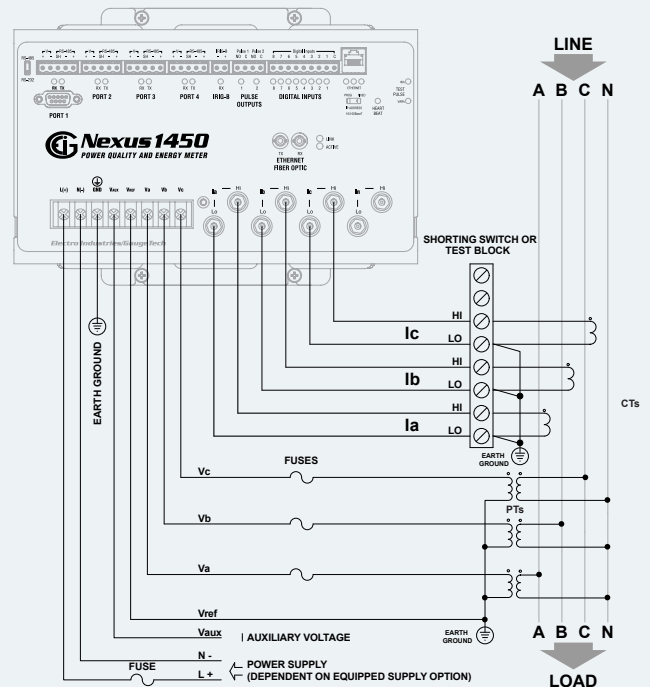

4 WIRE WYE, 3 ELEMENT WITH 3 PTs AND 3 CTs

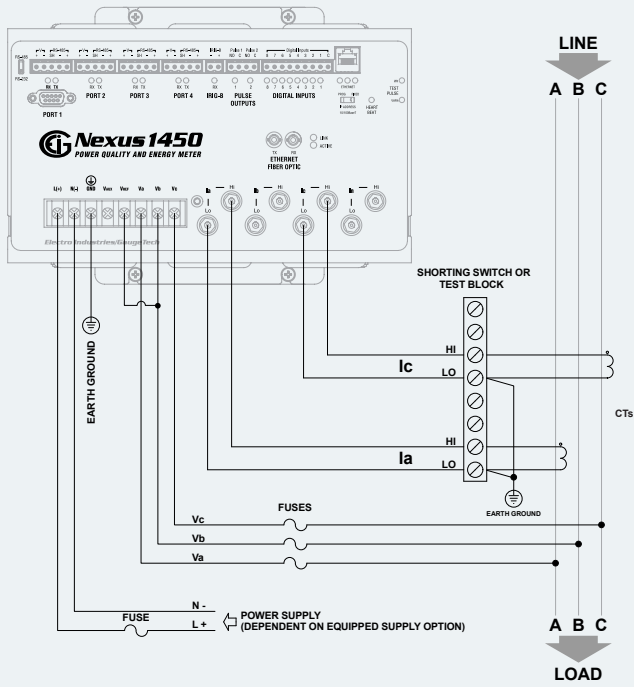

3 WIRE, 2 ELEMENT DELTA DIRECT VOLTAGE WITH 2 CTs

**Important:** The Potential between A, B, C and GROUND must be less than 347 V AC.

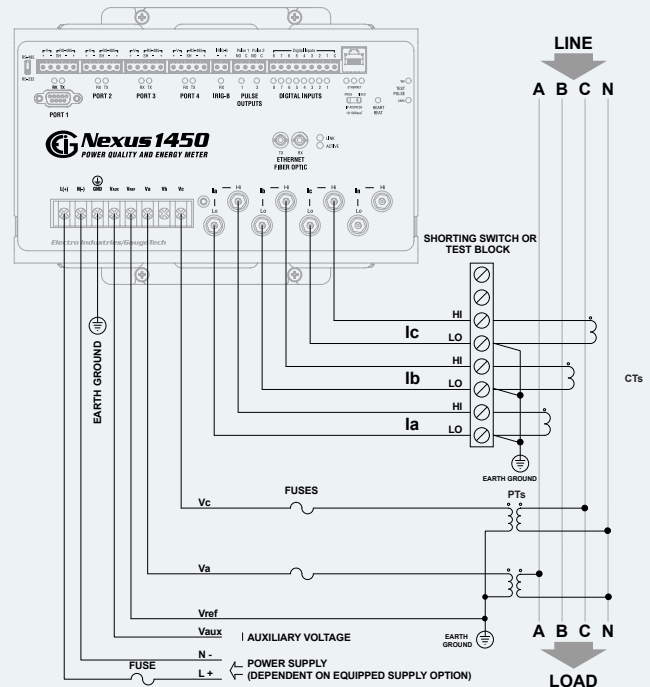

3 PHASE, 4 WIRE 2.5 ELEMENT WITH 2 PTs, 3 CTs

## Voltage Input Range

- Absolute range between any voltage inputs: (20 to 720) V AC
- Pickup voltage: 5 V AC

## Isolation

- Voltage Inputs isolated to 2500 V AC

## Current Input Range

- Supports Class 2 and Class 20 in one input configuration
- Programmable to any CT ratio
- Fault current recording to  $\pm 80$  A peak
- Pick-up current: 1 mA

## Current Input Withstand Capability (at 23 °C)

- 100 A for 10 seconds
  - 300 A for 3 seconds
  - 500 A for 1 second
- Burden**
- Voltage Inputs: 5 M $\Omega$  per voltage input
  - Current Inputs: 0.028 VA per phase max at 20 A

## Frequency Ranges

- Nominal: (42.5 to 69.5) Hz
- Wide band: (20 to 500) Hz
- With wide band Frequency, some features are disabled- see meter manual.

## Environmental

- Operating temp: (-25 to +70) °C

- Storage temp: (-40 to +70) °C
- Humidity: Up to 95% RH non-condensing
- Protection Class: Meter - IP30; P70N Display - IP65, indoor use only

**Measurement Method**

- Programmable sampling rate up to 1024 samples/cycle
- High resolution, simultaneous sampling of all analog inputs
- Multi-Gain™ sensing method
- True RMS

**Accuracy Ratings**

- Energy measurement accuracy at 0.06% (0.025 A to 20 A at PF=1)
- Time clock: Accurate to 20 ppm at 23 °C
- Full accuracy specifications available in Nexus® 1450 Meter User Manual

**Control Power Requirements**

- D2 Option: (96 - 276) V @ 50/60 Hz or DC
- D Option: (18-60) V DC
- Burden: 20 VA max w/o I/O or display; 40 VA max with I/O and display

**Communication**

- Baud rate up to 115200 bps
- Programmable parity and stop bits
- Serial Communication

protocols: Modbus ASCII/RTU, DNP3 Level 2

- Ethernet: Modbus TCP, DNP3 Level 2, SNMP, SMTP, HTTP, and HTTPS; DHCP, IPv4/IPv6 Support
- RJ45 Ethernet port 10/100BaseT
- Fiber Optic port 100Base FX
- 4 RS485 ports
- RS232 port (shared)
- RS485 Serial ports have 18 V DC output for I/O
- Optional P40N+ display offers USB Type B communication

**Shipping**

- Total shipping weight: approx. 5 lbs (2.2 kgs)
- Shipping container dimensions: 14" x 10" x 6" (35.6 cm x 25.4 cm x 15.2 cm)
- Displays and I/O modules ship in separate containers.

**Compliance**

- ANSI C12.20 - 2015 0.1 Accuracy Class
- IEC 62053-22 Accuracy, 0.2S
- IEC 62053-23 Ed. 1, Class 2
- CISPR 11 2009, Class A,

FCC Part 15 Subparts A and B 2018\*

- IEC/EN 61000-3-2 Class A 2014 (Harmonic Current Emissions)\*
- IEC/EN 61000-3-3 2013 (Voltage Fluctuations and Flicker)\*
- ICES-001 2006\*
- CE (EN/IEC 61000-6-2 & EN/IEC 61000-6-4 & EN/IEC 61236-1) EMC General requirements
  - IEC 61000-4-2 Ed. 2 (Electrostatic Discharge)\*
  - IEC 61000-4-3 Ed. 3.2 (Radiated EM Immunity)\*
  - IEC 61000-4-5 Ed. 3 2014 (Surge Immunity)\*
  - IEC 61000-4-6 Ed. 4 2013 (Conducted Immunity)\*
  - IEC 61000-4-8 Ed. 2 2009 (Magnetic Immunity)\*
  - IEC 61000-4-11 Ed. 2 2004 (Voltage Variations Immunity)\*
  - IEC 61000-4-29 Ed. 1 2000 (Voltage Dips and Interruptions)\*

• IEC 61000-4-30 Class A Ed. 3 (Power quality measurement methods) (PSL Labs Certified)\*

- IEC 61000-2-4 (Compatibility Levels)\*
- IEC 62586-2 Ed. 2 2013 (PQ Measurement in Power Supply Systems)\*
- IEC 61000-4-7 General guide on Harmonics and Interharmonic Measurements and Instrumentation\*
- IEC 61000-4-15 Flicker Measurements\*
- EU Directive 2011/65/EU (RoHS 3 Directive)
- REACH Compliant
- Certified to UL/IEC 61010-1, UL/IEC 61010-2-030, CSA C22.2 No.61010-1, UL File: E250818

**External I/O Modules**

- 1mAON4: 4 Analog Outputs, 0±1 mA
- 1mAON8: 8 Analog Outputs, 0±1 mA
- 20mAON4: 4 Analog Outputs, 4-20 mA

- 20mAON8: 8 Analog Outputs, 4-20 mA
- 8AI1: 8 Analog Inputs, 0±1 mA
- 8AI2: 8 Analog Inputs, 0±20 mA
- 8AI3: 8 Analog Inputs, 0±5 V DC
- 8AI4: 8 Analog Inputs, 0±10 V DC
- 4RO1: 4 Relay Outputs
- 4PO1: 4 Solid State Pulse Outputs
- 8DI1: 8 Digital Status Inputs
- PSIO: Power Supply for up to 4 additional I/O modules
- MBIO: I/O mounting bracket (must be ordered with external I/O module)

**Note:** Please see the Nexus® 1450 Meter User Manual for complete specifications.  
\*Third party lab tested

**Ordering Information** - All fields must be filled in to create a valid part number.

	Nexus® Base Meter	Control Power	Frequency Range	Virtual Switch
<b>Option Numbers:</b>	-	-	-	-
<b>Example:</b>	Nexus® 1450	D2	60	V1
	<b>Nexus® 1450</b> (Meter)	<b>D2</b> Universal (96-276) V @ 50/60 Hz or DC	<b>60</b> 60 Hz System	<b>V1</b> Standard Nexus® 1450 Meter / 512 MB logging memory / 512 s/c
		<b>D</b> (18-60) V DC	<b>50</b> 50 Hz System	<b>V2</b> V1 + 1200 MB logging memory / 1024 s/c

**Additional Options** - \* Must be ordered with an external I/O module.

Software					
<b>COMPQA6P1Y</b>	CommunicatorPQA® 6 Configuration Software - Single-Computer License (One Site)		<b>ENERGYPQA-1Year</b>	AI Driven Energy Management Solution	
Displays and Mounting					
<b>P40N+</b>	Multifunction LED Display/Master	<b>P43N+</b>	Watt/VAR/PF Display Slave	<b>SMKP70N</b>	Color Touchscreen LCD Display
<b>P41N+</b>	Amp Display Slave	<b>P70N</b>	Color Touchscreen LCD Display	<b>E171103</b>	DIN Rail Mount Kit for Nexus® 1450 meter
I/O Modules					
<b>1mAON4</b>	4 Analog Outputs, 0±1 mA	<b>8AI1</b>	8 Analog Inputs, 0±1 mA	<b>4RO1</b>	4 Relay Outputs
<b>1mAON8</b>	8 Analog Outputs, 0±1 mA	<b>8AI2</b>	8 Analog Inputs, 0±20 mA	<b>4PO1</b>	4 Solid State Pulse Outputs
<b>20mAON4</b>	4 Analog Outputs, 4-20 mA	<b>8AI3</b>	8 Analog Inputs, 0±5 VDC	<b>PSIO*</b>	Power Supply for Additional I/O Modules
<b>20mAON8</b>	8 Analog Outputs, 4-20 mA	<b>8AI4</b>	8 Analog Inputs, 0±10 VDC	<b>MBIO*</b>	I/O Mounting Bracket

1800 Shames Drive  
Westbury, NY, 11590

**1-877-EIMETER**  
(1-877-346-3837)

**Tel:** 516-334-0870  
**Fax:** 516-338-4741

**Email:** EIG\_sales@hubbell.com  
**Website:** www.electroind.com

