

Nexus[®] 1262/1272

Revenue Energy Meters with Power Quality

Accu-Measure™ Technology



Nexus[®] 1262
Economical Meter with
Advanced Communication



Nexus[®] 1272
Performance Meter with
Advanced Communication
and Power Quality

Highly Advanced Revenue Meter

- 0.06% Wh Accuracy
- Precision Auto-calibrating Metrology
- Multipoint Compensation Factors
- Pulse Totalizers
- Load Profilers and I/O
- MV90 Compatible
- Available in Socket, A-Base, and Switchboard Form with Draw-out Meter Cradle

Highly Advanced Communication

- Up to 4 Com Ports
- Modbus RTU and Modbus TCP/IP
- DNP3 Serial and Ethernet
- Web Server and Email on Alarm
- High-speed Power Quality Waveform Recorder
- 9 Levels of Password Security



Advanced Measurement

The Nexus® 1262/1272 meters are designed for demanding smart grid and intelligent substation applications. They provide one of the most profound analyses of electricity available in a socket form revenue meter. The units offer extensive advanced monitoring features to meet the most critical power monitoring requirements. Using advanced DSP technology, the meters provide immediate and stored revenue power data coupled with superior power quality and communication. The Nexus® 1262/1272 meters' basic package starts where most other meters end. The meters' standard features provide the ability to meet both your current and future advanced metering needs.

Accu-Measure™ Auto-Calibrating Metrology for Unmatched Accuracy

- Energy and Power Accuracy to within 0.06%
- Auto-calibration over Time
- Automatic Temperature Drift Adjustments
- Improved Stability and Better Long-term Accuracy

4 Quadrant Measurement

The unit is a full four quadrant meter. It gathers hour data information in every quadrant.

- kWh Delivered and Received
- kVAh in Each Quadrant
- kVARh in Each Quadrant
- Q Hours

	1 sec	Thermal	Block	Rolling	Predicted
Watts	349.37	348.60	347.88	348.10	348.43
VARS	12.41	10.73	10.65	10.72	10.73
VA	349.59	348.77	348.04	348.26	348.59
PF	0.999 LAG	0.999 LAG			

Power
Totals | 1 sec updated per phase | Thermal per phase | Uncompensated
Poling 00110022
OK Print

4 Quadrant Measurement

Time of Use

The 1262/1272 offers robust time of use functionality. Standard capabilities include:

- 8 TOU Schedules
- 4 Seasons/Year
- 20 Year Calendar
- Prior Month and Prior Season
- Programmable Freeze Registers

Transformer and Line Loss Compensation

Loss compensation adjusts for both copper and iron losses with a simple user setup.

Load Aggregation/Universal Metering

Using standard pulse inputs, the Nexus® 1262/1272 meter can count pulses from external meters and accumulate usage. The pulse inputs can be used to totalize electrical usage and utility values, such as water or gas use data.

- 8 Pulse Inputs
- Individual Accumulating Registers
- 4 Totalizing Registers (Add or Subtract)

Source	Totals	Average	Maximum	Time Stamp	Acc To
Input Acc 1	9999.999	1.00	9.99	24/09/10 11:30:33	Max Set
Input Acc 2	9999.999	1.00	9.99	24/09/10 11:30:33	Max Set
Input Acc 3	9999.999	1.00	9.99	24/09/10 11:30:33	Max Set
Input Acc 4	9999.999	1.00	9.99	24/09/10 11:30:33	Max Set
Input Acc 5	9999.999	1.00	9.99	24/09/10 11:30:33	Max Set
Input Acc 6	9999.999	1.00	9.99	24/09/10 11:30:33	Max Set
Input Acc 7	9999.999	1.00	9.99	24/09/10 11:30:33	Max Set
Input Acc 8	9999.999	1.00	9.99	24/09/10 11:30:33	Max Set
Watt Hour	Energy				Acc To
Aggregator	Totals	Average	Maximum	Time Stamp	Max Set
Agg Total 1	99999.99	1.00	9.99	24/09/10 11:30:33	Max Set
Agg Total 2	99999.99	1.00	9.99	24/09/10 11:30:33	Max Set
Agg Total 3	99999.99	1.00	9.99	24/09/10 11:30:33	Max Set
Agg Total 4	99999.99	1.00	9.99	24/09/10 11:30:33	Max Set

ON Print Export

Load Aggregation/Universal Metering

CT and PT Compensation

The Nexus® units compensate for errors in current transformers and potential transformers.

- 8 Pulse Inputs
- Voltage Compensation
- Multipoint Current Compensation
- Multipoint Phase Angle Compensation
- Better than 0.01% Resolution

Multiple Demand Windows

The Nexus® 1262/1272 meter simultaneously monitors five demand structures.

- Block Window Demand
- Rolling Window Demand
- Predictive Demand
- Thermal Demand
- Cumulative Demand
- Interval Length from 1 Second to Many Hours
- End of Interval Pulse Output
- End of Interval Pulse Input
- Cold Load Pickup

Timestamped Max Demand

The units gather demand information for all power values. Each value is date/timestamped.

- kW Demand, Delivered & Received, Max/Min
- kVAR Demand, Delivered & Received, Max/Min
- kVAR Coincident with kW Demand
- kVA Demand, Max/Min
- Current Demand, Max/Min
- Voltage, Max/Min

Configure Custom Display for Any Application

Unique Display Configurator

The Nexus® 1262/1272 meter is designed with one of the industry's most advanced LCD display configuration technologies, which lets you choose from multitudes of pre-programmed display screens and create fully customized displays for any specific application. Build from scratch, as needed, user display screens that provide information on anything the meter measures (which is almost everything). Use the display to view not only electrical, but water or gas usage. Also use the meter as an aggregator for total usage. Provide ambient and transformer temperature or any other desired critical operational data on the display.

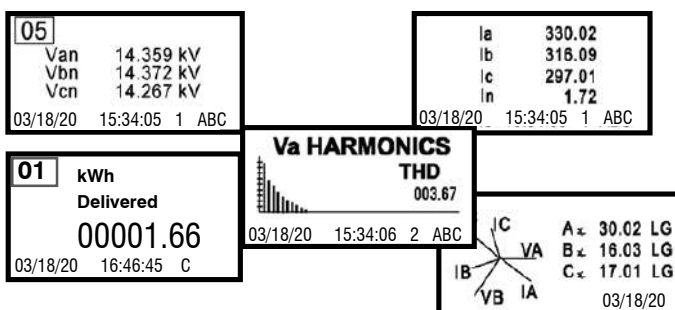

3 Display Modes/75 Screen Slots - The meter's memory has 75 slots for custom and/or pre-programmed screens. These slots can be allocated to any view mode with any number of slots used in each of the modes.

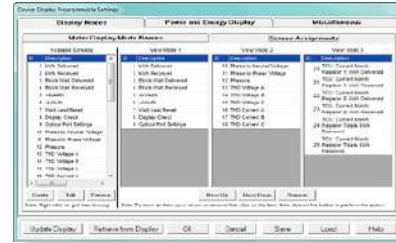

Highly Configurable Display Assignments

Custom Display Configurator to Create Exactly What's Needed

- Make Custom Screens Based on Modbus Registers
- Make Any Custom Labels
- Customize Screen Numbering and Order
- Display Up To 5 Pieces of Information per Screen
- Display Water, Gas, and Other Types of Usage
- Add Diagnostic Information

Normal Mode

- MWh Delivered and Received
- kVARh Delivered and Received
- kVAh Delivered and Received
- Peak Rolling Window Demand
- Peak Block Window Demand

Time of Use Mode

- MWh and kW Demand Delivered and Received Total
- kVARh and kVAR Demand Delivered and Received for Each Register
- kVAh Delivered and Received for Each Register
- kVAh Delivered and Received Total

Pre-configured Diagnostic Screens - Select from a large offering of diagnostic screens such as:

- Voltage
- Phase Angles
- Harmonic Magnitudes
- Firmware Versions
- Meter Status
- Phasor Diagram
- Watts/VARs
- Many More Diagnostic Screens Available

Advanced Communication and I/O Capabilities

Standard Multi-port Communication

- Optical Port
- 2 RS485 Serial Ports
- Modbus RTU/ASCII, DNP3 Level 2
- Speeds Up to 115200 bps

Optional Communication

- 10/100BaseT Ethernet (INP200)

Standard I/O

- IRIG-B 1 ms Time Synchronization to GPS Satellite Clock
- 4 Internal KYZ Pulse Outputs
- 8 KYZ Pulse/Status Inputs

Optional External I/O

Connect multiple external I/O Modules for enhanced I/O capability.

- Analog Outputs
- Analog Inputs
- Digital Status Inputs
- KYZ Outputs
- Relay/Alarm Outputs



Control Capabilities

- ElectroLogic™ Provides User-definable Control Outputs
- Action and/or Alarm on Abnormal Condition
- Action on Boolean Logic Combinations of Inputs or Electrical Conditions

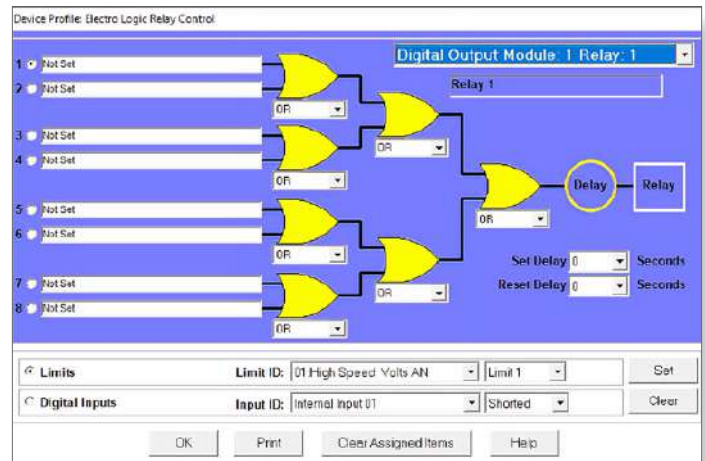

DNP3 Level 2

The Nexus® 1262/1272 meter provides advanced DNP3 protocol implementation. DNP3 is available on the serial and Ethernet ports. EIG's Nexus® 1262/1272 meter complies with all DNP3 Level 1 and Level 2 certification requirements plus a host of additional features, including:

- **Up to 104 Measurements:** 64 Binary Inputs, 8 Binary Counters, 32 Analog Inputs Mapped to DNP Static Points in the Customizable DNP Point Map
- **Up to 16 Relays and 8 Resets:** Can Be Controlled through DNP
- **Report-By-Exception Processing:** (DNP Events) Deadbands Can Be Set on a Per-point Basis
- **250 Events in Combinations of Four Events:** Binary Input Change, Frozen Counter, Counter Change, Analog Change
- **Freeze Commands:** Freeze, Freeze/No-Ack, Freeze with Time, Freeze with Time/No-Ack, Scheduled Freeze Command
- **Freeze with Time Command:** Enables the Nexus® Meter to Have Internal Time-driven Frozen Counter and Frozen Counter Event Data
- Third Party Certification is Available
- 5 Simultaneous DNP3 Level 2 Ethernet Sessions

Draw Out Switchboard Case - SWB3 Relay Case Replacement

EIG has designed its own switchboard case. It is a superior direct replacement to the existing General Electric style S1 relay case-mounted meters. The case has the same measurements as the S1 case and its wiring follows industry conventions, eliminating the need for new wiring. Our unique design improves on the old classic case with many new features, including:

- Draw out meter cradle for easy testing and replacement
- Easy-remove paddle to simplify installation
- NEMA 4X-rated cover for use in outdoor substation control panels
- One button cover release for simpler installation and testing

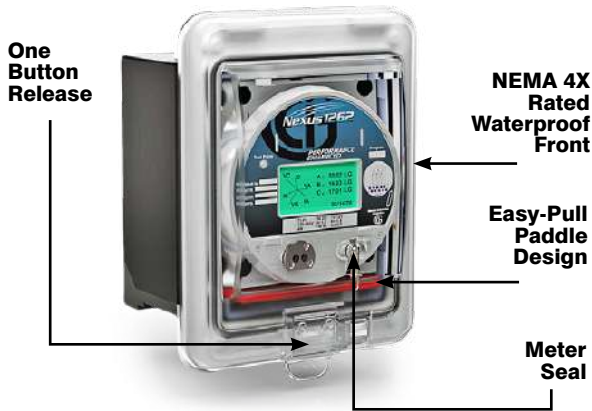

Advanced Features Include:

- Fully Customizable Webpage Development
- Direct Webpage Hosting with Live Readings
- Multiple Meter Hosting on One Page
- Read Direct from Meters (No Server Software Needed)
- No ActiveX Controls or Java Downloads
- IT Dept Friendly: Works through Firewalls; Low-Cost/High Functionality
- Instant Alarm Emails – Direct from the Meter

WebExplorer (Directly Host Metering Data)

EIG's WebExplorer provides you with direct access to all power data through a standard HTML format, without needing to download ActiveX controls or Java applets. WebExplorer is fully programmable, so you can customize your own SCADA quality webpages, graphics, and configurations.

- Easily Incorporated into Any Existing Web Applications
- Fully Programmable Webpage Generator
- Brings in Direct XML Links, Displaying Many Meters on One Page



Total Web Solutions

Providing Metering Data Integration with the Web

Total Web Solutions is an advanced Ethernet communication architecture that lets you design custom webpages, display metering data, and host your meter power information website directly on a Nexus® meter. The Nexus® meter hosts the web data without any need for dedicated server software, ActiveX Controls or Java Applets. The meter does the data collection, the formatting, and the page hosting.

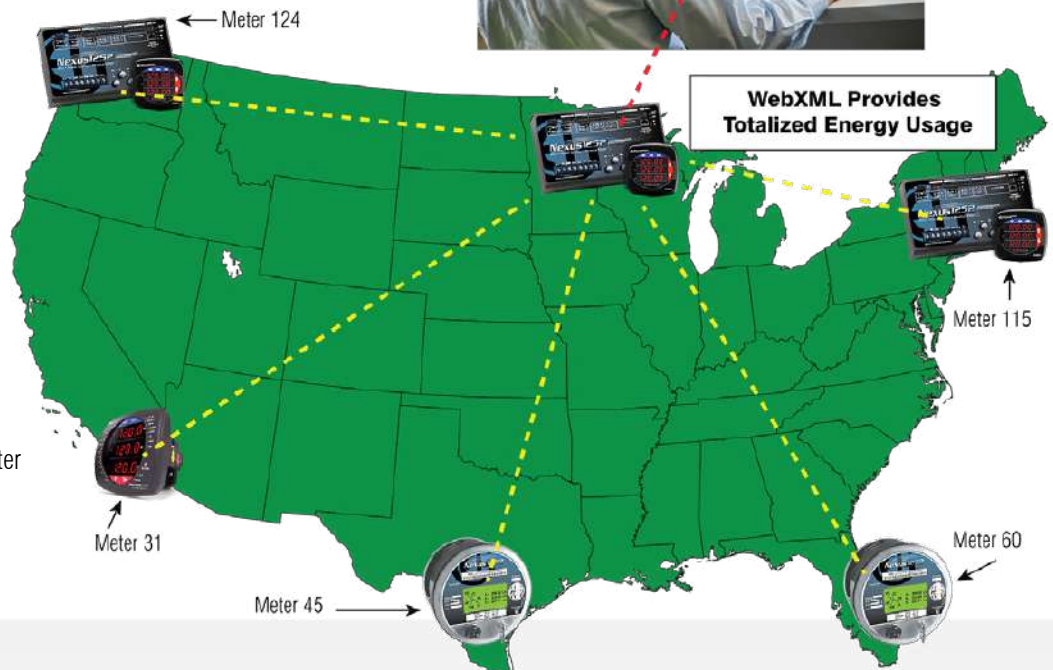

WebXML

- Automatically Process and Present Data in Readable Format
- Add Scaling Factors, Multipliers or Other Desired HTML Capability
- Display Data from Host Meter and/or any Other Meter Using Modbus RTU or TCP/IP (WebReacher)
- Customized Programming
- Easily Viewed by Different Applications
- Modbus Data Concentrator

WebReacher

With EIG's exclusive WebReacher technology, you can now access remote meters around the world, retrieve data, and consolidate it onto one webpage or web site without any separate software, SCADA package, client-side ActiveX controls, or Java Applets.

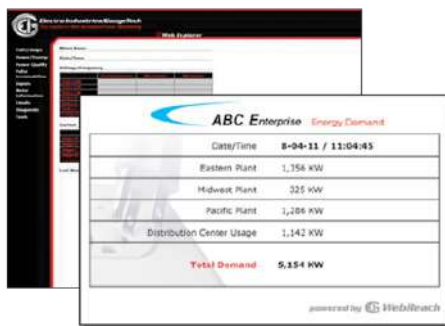

WebAlarm - Email Alerts

- Real Time Alerts
- Simultaneous Emails to Multiple Recipients
- Update Users on Virtually Any Abnormality
- Uses Standard SMTP – Just Assign Email Addresses
- Shows the Last 10 Emails on Web Site for Later Investigation

WebMod (Open Architecture 3rd Party Integration)

The 10/100BaseT design allows the unit to speak with 12 simultaneous sockets of Modbus TCP. EIG's WebMod features Modbus TCP open protocol that can be easily integrated with most other software or hardware. And with the built-in Modbus data concentrator, you can poll up to 8 devices or 512 unique polling items from any device that can speak Modbus RTU and/or Modbus TCP protocols. You can also view data from multiple meters, supplied by the master meter, in your web browser.



WebDNP

Using this feature, you can gain access to the meter speaking native DNP3 Level 2 over Ethernet. This allows the unit to open an exclusive network socket for DNP3. All other meter web features are available simultaneously with this feature.

Nexus® 1272 Meter's Advanced Power Quality Analysis Pinpoints Electrical Reliability Issues

The processing capability and accuracy of the Nexus® 1272 meter makes it possible to gather power quality information with unmatched precision. The Nexus® 1272 unit is ideally suited for application on all critical loads. From health care to micro-electronics, the 1272 has what it takes to capture every anomaly. This ensures that when there is a power problem, you have the information required to act. All Power Quality logs are timestamped to the nearest millisecond to ensure accurate recording. The meter's Advanced Download Logic collects only new data, to minimize download times.

Event/Out of Limit Log

- Records 1024 Events
- Out of Limit Recording
- High-speed Input Event Recording
- Outage Detection
- Extensive Limit Setting Capabilities with Multiple Limits per Selected Quantity

Waveform Log

The waveform recording capability of the Nexus® 1272 unit is unparalleled by any other meter. Waveform records of this quality have historically been reserved only for transmission lines. The power of the Nexus® 1272 meter now makes this quality available to your critical customers.

- Extraordinary Resolution through 16-bit A/D Input
- Sample Rates from 16 to 512 Samples per Cycle
- Total Recording Time Over 100 Seconds
- Up to Six Channels
- Voltage and Current Triggers
- External Event Trigger
- Voltage Surge/Sag Recording
- Current Fault Analysis

Harmonic Distortion Analysis

- Log Harmonics into Historical Log for Later Analysis
- Recorded Waveforms Provide Harmonics to the 255th Order
- View Waveform Records

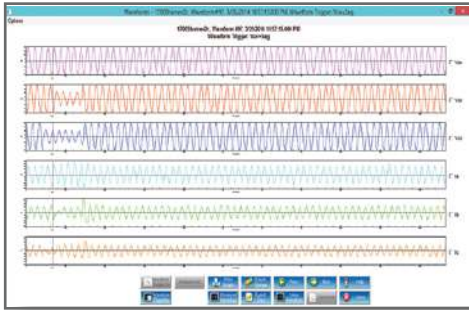

CBEMA/ITIC Log

The separate CBEMA/ITIC Log captures all voltage transients that fall outside these standards. The onboard log holds 1024 events. The data is downloaded to a separate log in the meter database for easy analysis. See all voltage disturbances on one screen through CommunicatorPQA® software.

- Sag/Swell Analysis
- Transient Recording

System Performance and Customer Reliability Analysis

The accuracy and precision of the Nexus® 1272 meter, coupled with its extraordinary logging capability, makes it an ideal tool for system performance and reliability analysis. For the first time at the revenue metering site, users have the accuracy and precision of a digital fault recorder without the expense. The Nexus® 1272 meter's 16-bit ADC accuracy and resolution for waveform records exceeds many digital fault recorder products. Combine the Nexus® 1272 unit with EIG's suite of software solutions to further expand the level of understanding during any monitoring situation.

CommunicatorPQA® Software Fault Analysis

- Compares Multiple Fault Records
- Measures Waveform Traces
- Inserts Timing Marks to Analyze Waveform Transients
- Displays CBEMA Logs
- PQDIF File Format Converter Allows Nexus® Data to be Read by Standard EPRI Power Quality Viewing Software
- COMTRADE File Converter Changes Fault Records to Standard Fault Analysis File Formats

At the Interchange Point

The Nexus® meter gives you the power of a sequence of events recorder on every transmission line or interchange point. The unit is always watching and has extended memory capability which can record multiple faults, or even frequency swings, during stability problems. Capture all voltage and current readings. Download the data and open the files with CommunicatorPQA® software or using the EnergyPQA.com® cloud-based energy management solution. Compare multiple channels, measure amplitudes and timing with millisecond resolution, and see system reliability events that lasted for several seconds.



Test Protective Equipment

Need to test protective equipment performance? Simply take the Nexus® record and convert it to COMTRADE format. Upload the file directly to protective test equipment to verify relay performance.

For the Customer

When that key customer calls, simply perform a download from the Nexus® 1272 meter. In a few minutes, all the data related to any event is on your desktop, letting you find the answers the customer needs.

Need to perform a more detailed evaluation? Simply open the viewer to look at the waveforms and see exactly what happened to voltages and currents throughout the event. Only the Nexus® meter provides precise pictures for many seconds.



Data and Event Monitoring/ Recording

Multiple Memory Logs

Nexus® meters provide many logs to record historical, alarm and system event data. These logs can be used for profiling, recording events, and logging electrical power parameters over time. Additionally, using the advanced I/O available with the product, you can also log process measurements, including temperature, pressure, flow, etc.

Two Historical Trend Logs

These logs allow you to trend virtually any electrical parameter over time. This includes all electrical and I/O parameters.

- Up To 64 Values per Log
- Programmable Trend Times
- Provides Magnitude and Duration of Event
- Millisecond Resolution
- 2 Separately Programmable Logs
- Separately Recorded Time Base
- Records Alarms for Electrical and I/O Channels

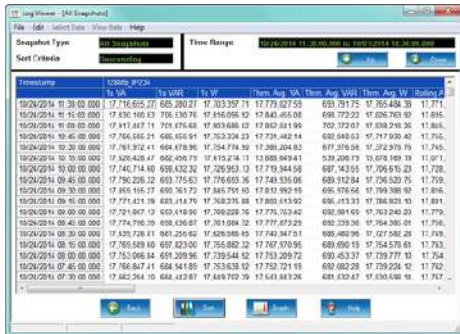

Historical Trending

Out of Limits Log

This log records all out-of-limit alarms, including the magnitude and the duration of the alarm.

System Events Log

The unit records the following system events in this anti-tampering log:

- Power Up
- Power Down
- Password Access
- Password Modification
- Change of Programmable Settings
- Change of a Run Time
- Change of Clock Time by Communication (Modbus or DNP3)
- Test Mode Usage
- Meter Resets (Logs, Max/Min, Energy)

Input Status Log

This log records when a digital status change occurred in either the internal or external inputs.

- Status Log for External Events
- Internally Labeled to Define Events

Control Output Log

This log records the logic and state that triggered a control output. The graphical log shows all the steps that led up to the event.

- Displays Pre- and Post-Analysis
- Internally Labeled to Define Events
- Advanced I/O Analysis

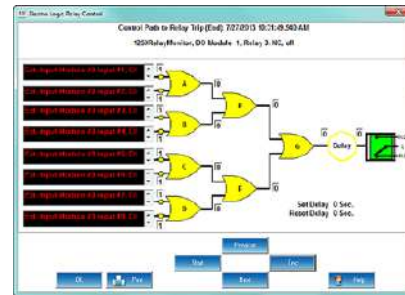

View Alarms, Status Changes and Control Events

Logging Specifications

Model	Historical Log 1	Historical Log 2	CBEMA/ITIC	Out of Limit Log	Waveform Log	Output Log	Input Log	System Events
1262	480 Days	133 Days	N/A	512	N/A	256	1024	1024
1272	555 Days	133 Days	512	1024	95	512	1024	1024

Note 1: Assumes logs store 4 scaled energy readings every 15 minutes.
Note 2: Number of events recorded (assumes 14 parameters monitored).

Note 3: Number of waveform records - each record may be from 8 to 64 cycles in duration, depending upon meter setup.

Meter Security

Advanced Meter Security

The Nexus® 1262/1272 meter offers advanced security, with multi-level passwords, an anti-tampering System Events log, and a physical seal on the meter.

Multi-level Secure Communication

The Nexus® 1262/1272 meter offers up to nine levels of password security to protect the meter from unauthorized use. The first step in enabling security is creating a Level 1 and Level 2 Password. The Level 2 password is the Admin, who can enable the multi-level security and create and configure the other user levels. Only the Admin user can enable or disable security. Each user level can be configured to enable specific capabilities, so that a Utility or other entity can control access to functions according to the type of user. For example, one user level may be able to create and change TOU calendars, while a different user level is able to read TOU data, but not change anything. Another user may be able to view TOU data and change settings, but not have access to the meter's external devices.

You can view the current protection status and the current user and user's capabilities through CommunicatorPQA® software. The functions that can be assigned to the user levels are as follows (the Admin user has access to all functions):

- Read TOU Calendars/Data
- External Device Access
- Modify Preset Energy
- Modify CT/PT Compensation
- Modify Date/Time
- Modify TOU Calendars
- Update Firmware
- Modify Programmable Settings
- Retrieve Specific Logs
- Reset Demand/Energy
- External Relay Control
- Manual Waveform Capture
- Reset Logs

Physical Sealing and Sealing Switch

The Nexus® 1262/1272 meter offers a Sealing Switch, which lets you add additional restriction to accessing meter functions. The Sealing Switch requires buttons to be pressed before the user can enter a password and configure the meter. It adds another layer of security to the meter, since the button is located under an area that can be secured with a physical seal, which would indicate tampering if removed. It also necessitates someone being present at the meter location. The Sealing Switch is enabled through CommunicatorPQA® software. The Nexus® 1262/1272 meter's Sealing Switch restricts access to resetting of logs, Max/Min, Energy, TOU, and related features; and enabling/disabling passwords.

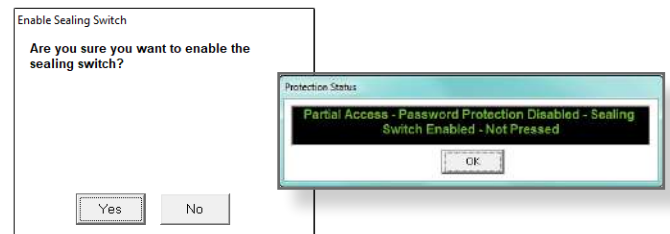
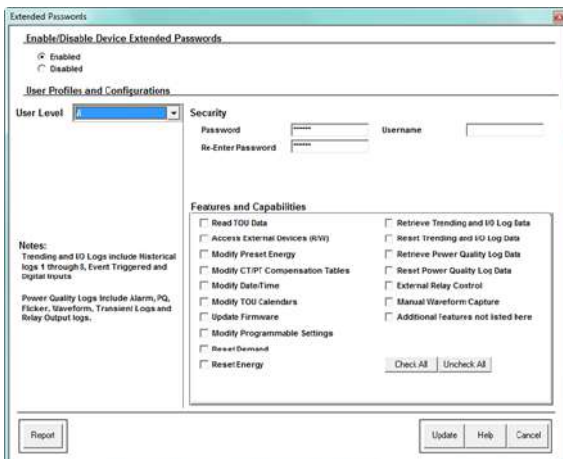

Supported Meter Forms		
Form	Rated Voltage	Hookup
9S	(0-277) V L-N	3E, 4 wire, Wye
36S	(0-277) V L-N	2½ E, 4 wire, Wye
45S	(0-480) V L-L	2E, 3 wire, Delta
SWB3	(0-277) V L-N	Programmable (Universal Forms)
9A	(0-277) V L-N	A Base Form

Accuracy	
Parameter	Records
Voltage	0.02%
Current	0.05%
Frequency	0.001 Hz
W	0.06%
Wh @1.0 PF	0.06%
Wh @0.5 PF	0.10%
VAR	0.10%
VA	0.10%
PF	0.10%

Dimensions and Mounting

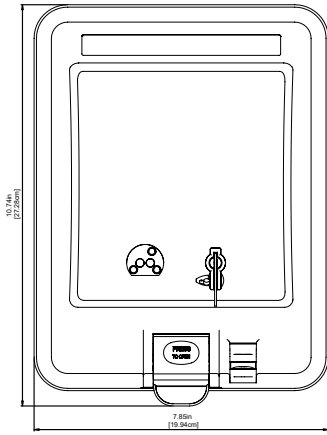

Nexus® 1262/1272 Switchboard Case
Front View

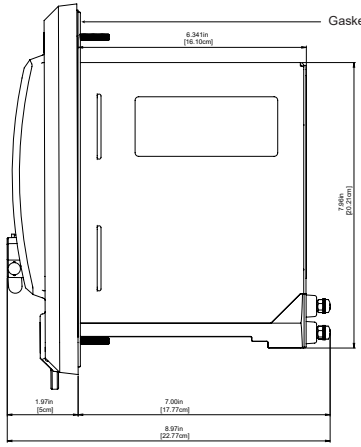

Nexus® 1262/1272 Switchboard Case
Side View

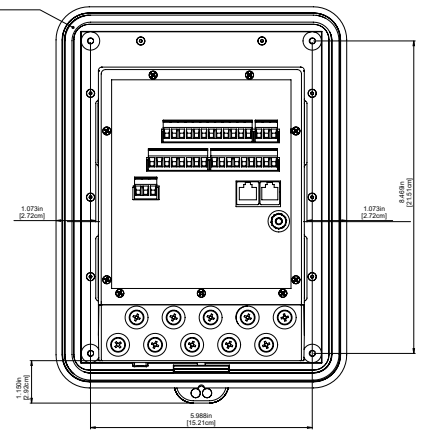

Nexus® 1262/1272 Switchboard Case
Back View

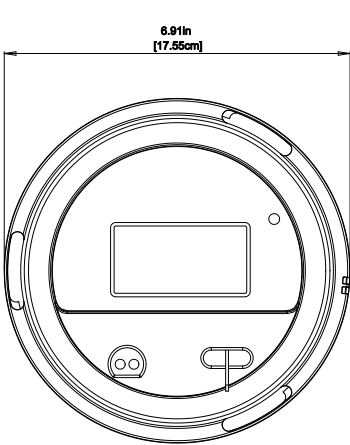

Nexus® 1262/1272
Socket Meter - Front View

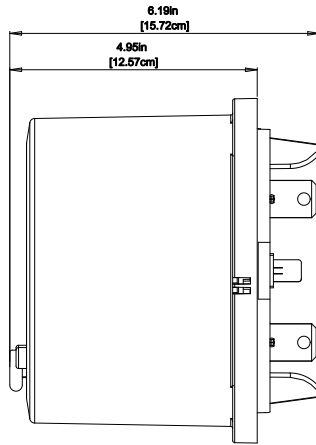

Nexus® 1262/1272
Socket Meter - Side View

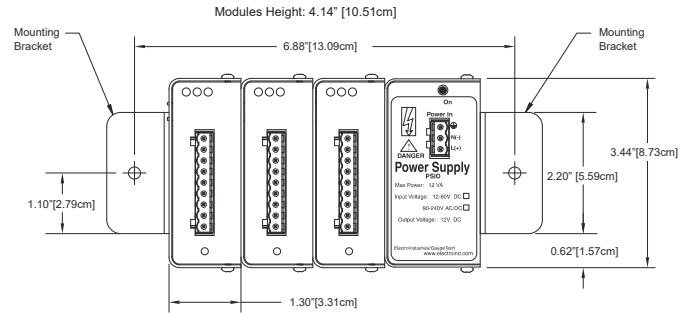

Nexus® I/O Modules
Front View

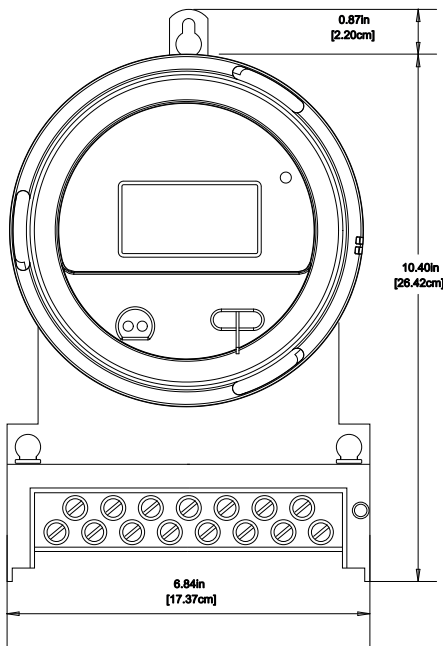

Nexus® 1262/1272 A-Base Case
Front View

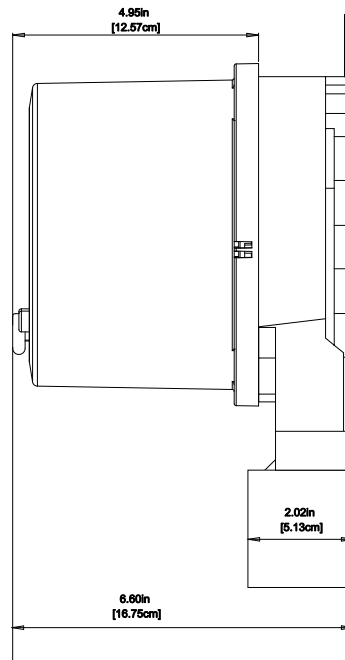

Nexus® 1262/1272 A-Base Case
Side View

Wiring Diagrams

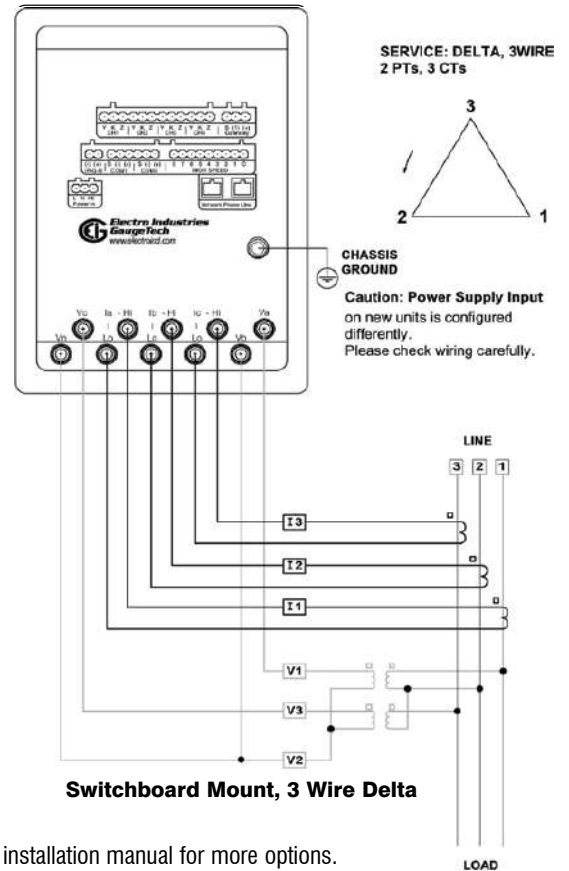
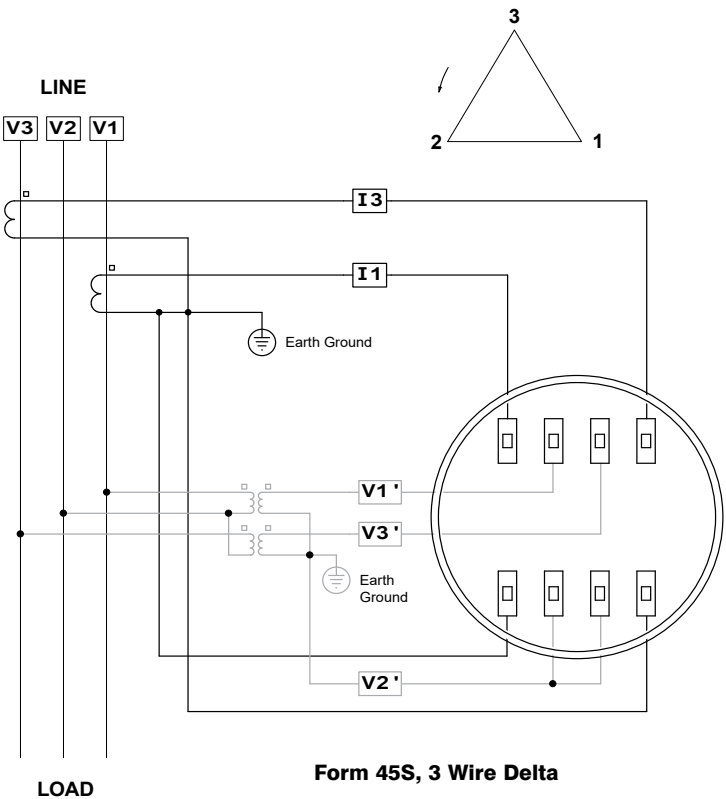
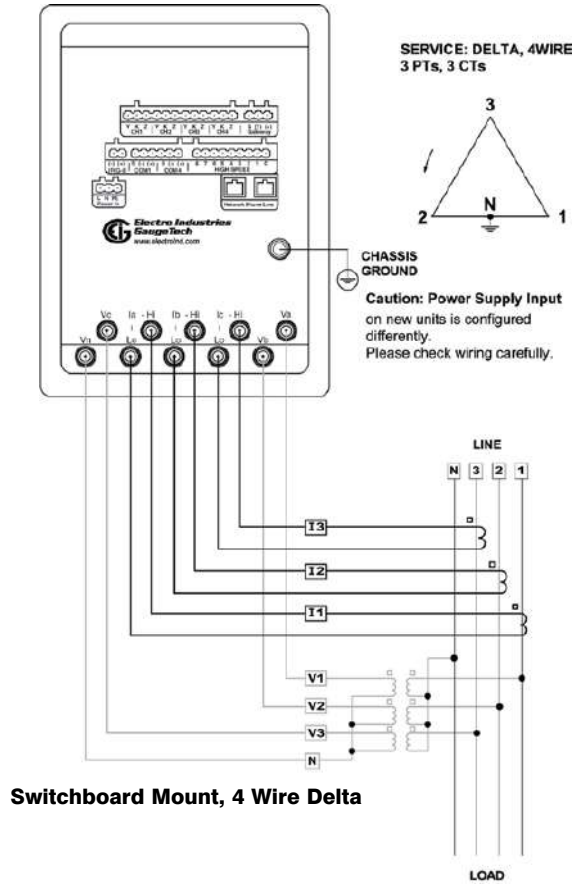
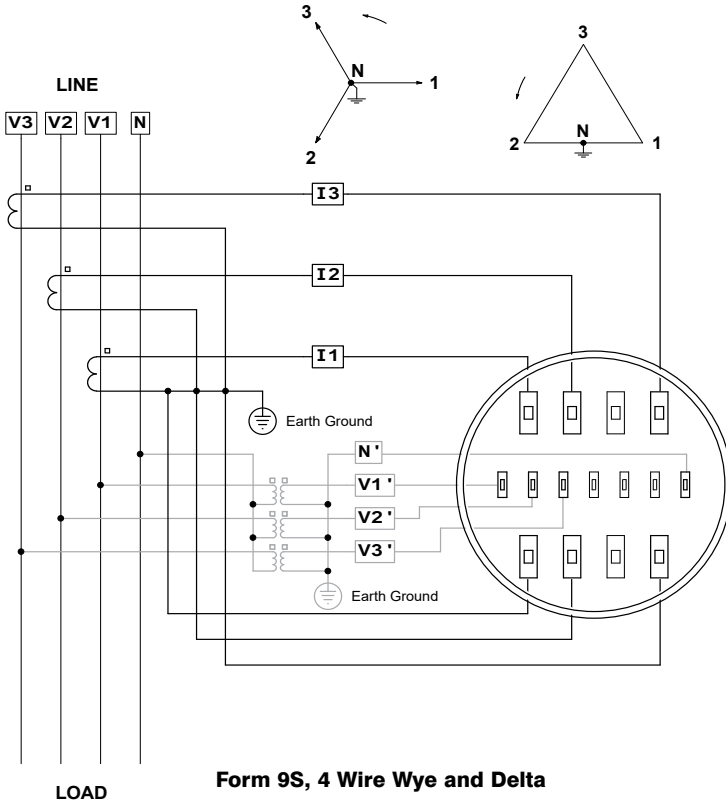

Note: Additional configurations are available - see the meter's installation manual for more options.

Specifications

Sense Inputs: Current (ac)

- Transformer (CT) rated
- 2 or 3 current inputs depending on Form (Ia, Ib, Ic)
- Class 2 – 1 A nominal CT secondary, burden 0.000312 VA@2.5 A
- Class 10, 20 – 5 A nominal CT secondary, burden 0.0125 VA@25 A
- 0.1% of nominal pickup current
- 120% over range of Meter Class
- Current surge withstand (at 23 °C) – 100 A for 10 seconds, 300 A for 3 seconds, 500 A for 1 second

Voltage (ac)

- Blade powered unit, standard voltage (option S): 480 V max between Vref and Va, Vb, Vc inputs; Burden total 12 VA max (including power supply); 600 V max between Va, Vb, Vc inputs
- Blade powered unit low voltage (option LV): 69 V max between Vref and Va, Vb, Vc inputs; Burden total 12 VA max (including power supply); 120 V max between Va, Vb, Vc inputs
- Externally powered units (options SE, DE): 480 V max between Vref and Va, Vb, Vc inputs; Burden 0.33 VA@576 V; 600 V max between Va, Vb, Vc inputs

- Input impedance 1 Mohm/phase
- 20% over range of rated voltage
- 2 V pickup voltage

External Power Supply Options Nominal Rating

- Standard external (option SE): (102-270) V AC/DC @50/60 Hz; 12 VA max
- Low voltage external (option DE): (18 to 60) V DC; 9 W max
- Separate power cord
- Switchboard meter is always separately powered (option SE or DE)

Isolation

- All Inputs and Outputs isolated to 2500 V
- Com ports isolated from each other to 1000 V

Sensing

- Accu-Measure™ Auto-calibration
- 16-bit A/D Inputs
- True RMS
- 8 Channel Sample and Hold

Memory

- All Meter Setup Parameters, Measurements & Logs Contained in Nonvolatile Memory

Standard Communication

- IR Port/ANSI
- Two RS485 Serial Ports
- Modbus RTU, Modbus ASCII, DNP3
- Data Speeds of up to 115200 bps
- Eight High-Speed Input Channels

Optional Communication

- Internal 10/100BaseT with Total Web Solutions
- Modbus TCP and DNP LAN/WAN

Internal 8ch Digital Inputs

- Type: Self Excited, for Dry Contacts Only
- Internal Wetting Voltage: 12 V DC Typical

Internal 4ch Solid State Outputs (KYZ)

- Type: Form C contacts, pulse or transition-based counts
- On Resistance: (23-35) Ω
- Peak Voltage: 350 V DC
- Continuous Load Current: 120 mA
- Peak Load Current: 350 mA (10 ms)
- Off State Leakage Current @350 V DC: 1: μ A
- Opto Isolation: 3750 V rms (60 Hz, 1 minute)

Clock Timing

- Internal Clock Crystal - Accuracy Better than 2 Minutes per Month
- IRIG-B Input for Synchronizing to External GPS Clock Signal - Accuracy Better than 1 ms per Month
- Line Frequency Clock Synchronization - Accuracy Better than 1 Second per Month

Environmental

- Operating Temperature: (-40 to +85) °C
- Display Temperature: (-20 to +60) °C
- Rain tight Lexan Cover, Outdoor-rated (Socket Meter)
- Temperature Specifications to Indirect Sunlight
- SWB3: NEMA 4X Rated Cover

Security

- Hardware Lock Secures Meter Settings
- Up to 9 10-Character Passwords
- One Password Controls Access to Read Meter Digitally
- Separate Password Controls Access to Program Meter
- Additional 8 level password sequence available by user configuration

Display

- Type: FSTN Liquid Crystal Display (LCD)
- Resolution: 128 x 64 pixels
- Size: 72 (H) mm x 32 (W) mm (2.8" x 1.26")
- Temperature: Operational from (-20 to +60) °C
- Backlight: LED (Green)

Shipping

- Weight: Socket: 10 lbs; Switchboard: 16 lbs
- Dimensions: Socket: 13" x 10" x 11"; Switchboard: 16" x 14" x 10.5"

Compliance

- ANSI C12.20 0.2 CL and C12.1
- IEC 62053-22 2003 0.2S*
- IEC 60687 (IEC 62053-22 and IEC 62053-23 0.2) KEMA Labs Certified*
- IEC 62053-11 2003*
- IS 14697:1999, (Reaffirmed 2004)*
- Measurement Canada Approved

Note: Please see Product manual for comprehensive specifications.

*Third party lab tested

Ordering Information - All fields must be filled in to create a valid part number.

	Model	Memory	Form	Class (Amps)	Frequency	Power Supply*	Optional Communication
Option Numbers:		-	-	-	-	-	-
Example:	Nexus® 1262	- A	- 9S	- 20	- 60	- SE	- INP200
	Nexus® 1272	A Advanced	9S	2 1 A Nominal CT Secondary	50 50 Hz	S Std Blade Powered	X No Expansion Port
	Nexus® 1262		36S	10 5 A Nominal CT Secondary	60 60 Hz	SE Std Ext (102-270) V AC @ 50/60 Hz or DC	INP200 Total Web Solutions
			45S	20 5 A Nominal CT Secondary		DE DC Ext (18-60) V DC	
			SWB3 (Switchboard)			LV 69 V AC Blade Powered	
			9A (A Base)				

*Switchboard Meter Only Supports SE or DE Options.

Accessory Options

I/O Modules		Power Options		Software Options			
1mAON4	4 Analog Outputs, 0±1 mA	8AI3	8 Analog Inputs, 0±5 V DC	PSIO	I/O Power Supply (Required with I/O Module)	COMPQA5P1Y	I/O Power Supply (Required with I/O Module)
1mAON8	8 Analog Outputs, 0±1 mA	8AI4	8 Analog Inputs, 0±10 V DC				
20mAON4	4 Analog Outputs, 4–20 mA	4RO1	4 Relay Outputs	Mounting Options		ENERGYQA-1Year	Cloud-based Energy Management Solution
20mAON8	8 Analog Outputs, 4–20 mA	4PO1	4 Solid State Pulse Outputs	MBIO	I/O Module Mounting Bracket Power Supply and Mounting Bracket (Required with any I/O Option)		
8AI1	8 Analog Inputs, 0±1 mA	8DI1	8 Digital Status Inputs				
8AI2	8 Analog Inputs, 0±20 mA						



Nexus® 1262 web page



Nexus® 1272 web page



1800 Shames Drive, Westbury, NY 11590 **1-877-EIMETER**
(1-877-346-3837) **Tel:** 516-334-0870 **Fax:** 516-338-4741
Email: sales@electroind.com **www.electroind.com**