

Shark 200

DATA LOGGING POWER
AND ENERGY METER



Revenue Metering

- Certified ANSI C12.20 0.2 Accuracy Class and IEC 62053-22 0.2S Energy Measurement Accuracy
- High Resolution Frequency Measurements - 0.001 Hz
- Transformer Line Loss and CT/PT Compensation
- Data Logging, Including Three Historical Logs with 64+ Parameters Each
- Designed for High Reliability and Ease of Use

Power Quality Metering

- Programmable Alarm Limits
- THD Monitoring and Harmonics Recording

- Waveform Recording of up to 512 Samples/Cycle, 170 Events

Communication & I/O

- Two Optional, Separately Addressable Ethernet Ports with Email on Alarm, Web Servers, and IP Whitelisting
- Standard IrDA and RS485 Port
- Modbus ASCII/RTU/TCP, DNP3, and IEC 61850 Protocols
- V-Switch™ Keys Add Functionality in the Field
- Field Upgradable I/O, Including Analog Outputs, Status Inputs, Control Relays, and Pulse Outputs



Applications

- Utility metering.
- Commercial metering.
- Substation metering.
- Industrial metering.
- Power generation.
- Campus metering.
- Submetering.*
- Analog meter replacement.
- Power quality studies.
- Disturbance recording.
- Load studies.
- Voltage recording.

* New York State approved for residential submetering.

Primary Revenue Metering

Certified 0.2% Energy Accuracy

The Shark[®] 200 meter is certified to ANSI C12.20 0.2 Accuracy Class and IEC 62053-22 0.2S measurement accuracy. It provides highly stable, precise, and reliable measurements that maintain accuracy over time. The meter has a standard energy test pulse for accuracy verification.

Accuracy Chart

Properly bill utility customers for energy usage, even if the meter is placed on the secondary side of the transformer.

Parameters	Accuracy	Display Range
Voltage L-N	0.1%	0-9999 Scalable V or kV
Voltage L-L	0.2%	0-9999 V or kV Scalable
Current	0.2%	0-9999 Amps or kAmps
+/- Watts	0.2%	0-9999 Watts, kWatts, MWatts
+/-Wh	0.2%	5 to 8 Digits Programmable
+/-VARs	0.2%	0-9999 VARs, kVARs, MVARs
+/-VARh	0.2%	5 to 8 Digits Programmable
VA	0.2%	0-9999 VA, kVA, MVA
VAh	0.2%	5 to 8 Digits Programmable
PF	0.2%	+/- 0.5 to 1.0
Frequency	+/- 0.007 Hz	(45 to 65) Hz
THD	+/- 2.0%	1 to 99.99%
% Load Bar	+/- 1 Segment	(0.005 to 6) A

Note: Applies to 3 element WYE and 2 element Delta connections.

CT/PT Compensation

To meet stringent accuracy requirements, users need to compensate for inaccuracies of instrument transformers in their system. The Shark[®] 200 meter has built-in features that provide CT/PT compensation through amplitude and phase angle adjustment.

Transformer/Line Loss Compensation

The Shark[®] 200 meter's transformer and line loss compensation (TLC) supports correct energy measurements when the meter is placed on the secondary side of the transformer. Compensate energy readings for TLC to perform accurate customer usage billing.

V-Switch™ Key Technology

The Shark[®] 200 meter has EIG's V-Switch™ key technology, which allows a user to upgrade features without removing the meter from service.

Feature	V-Switch™ Key					
	V1	V2	V3	V4	V5	V6
Multifunction Measurement with I/O Expansion	✓	✓	✓	✓	✓	✓
2 MB Data Logging		✓	✓	✓		
3 MB Data Logging					✓	
4 MB Data Logging						✓
Harmonic Analysis			✓	✓	✓	✓
TLC and CT/PT Compensation	✓	✓	✓	✓	✓	✓
Limit and Control Functions				✓	✓	✓
64 Samples per Cycle Waveform Recorder					✓	
512 Samples per Cycle Waveform Recorder						✓

Extensive Data Logging Capability

At V2 and higher, the Shark® 200 meter has up to 4 MB of data logging memory, used for historical trends, limit alarms, I/O changes, and sequence of events. The unit's real time clock timestamps all data in the instrument when log events are created.

Historical Logs

- Three assignable historical logs of 64+ parameters per log.
- Independently programmed trending profiles.

I/O Change Log

- Provides a timestamped log of any relay output or input status changes.
- 2048 events available.

System Events Log

To protect critical billing information, the meter records and logs the following actions with a timestamp:

- Demand/energy/log resets.
- Password requests.
- System startup.
- Log reads.
- Programmable settings changes.
- Critical data repairs.

Limit/Alarm Log

- Provides magnitude and duration of an event.
- Includes timestamp and alarm value.
- 2048 events available.
- Email on alarm capability with INP100S Ethernet card.

Limit Alarms and Control Capability

At V4 and higher, up to eight limits can be set on any measured parameter, including voltage and current unbalance.

- Based on % of full scale settings.
- Trigger relay outputs or emails for control.

High Performance Power Quality Analysis

Simultaneous Voltage and Current Waveform Recorder

At V5 and higher, the meter records up to 512 samples per cycle for a voltage sag or swell or a current fault event. It provides the pre- and post-event recording capability shown in the table below. Waveform records are programmable to the desired sampling rate. The meter's advanced DSP design allows power quality triggers to be based on a one cycle updated RMS. Up to 170 events can be stored until the memory is full. The meter stores waveform data in a first-in/first-out circular buffer to ensure data is always recording.

	Samples Per Cycle	Pre-Event Cycles	Post-Event Cycles	Max Waveforms per Event	Number of Stored Events
V5	32	16	48	128	85
	64	8	24	64	85
V6	128	4	12	32	170
	256	2	6	16	170
	512	1	3	8	170

Note: Sampling rate based on 60 Hz systems. For 50 Hz systems, multiply by 1.2.

Waveform Scope

The unit uniquely offers a waveform scope that lets you view the real time waveform for voltage and current. The waveform scope allows the meter to be used as a basic oscilloscope throughout a power system.

total surges, total sags, and duration, without retrieving waveform data. Timestamps are stored with millisecond accuracy.

Independent CBEMA or SEMI F47 Log Plotting

The meter stores an independent CBEMA or SEMI F47 log for magnitude and duration of voltage events. This lets you quickly view

Harmonic Recording to the 40th Order

The Shark® 200 meter provides advanced harmonic analysis to the 40th order for each voltage and current channel, in real time. Using the stored waveforms, harmonic analysis is available to the 255th order.

Standard Communication Capability

The Shark® 200 meter provides two independent communication ports with advanced features.

Rear Mounted Serial Port with KYZ Pulse

- **RS485** - This port allows RS485 communication using Modbus or DNP3 protocols. Baud rates are from 1200 to 57600.
- **KYZ Pulse** - In addition to the RS485 port, the meter also includes pulse outputs mapped to absolute energy.

Front Mounted IrDA Communication

The meter has an optical IrDA port, that allows you to program it with an IrDA-enabled laptop.

Field Communication Capability

The Shark® 200 meter's flexible communication architecture integrates directly into most existing software systems. In addition to its standard communication, the meter offers extensive communication and I/O expandability through its two universal option card slots. The meter accepts and auto-detects new I/O cards even after installation. Up to two cards of any type can be used per meter.

1. INP100S: 100BaseT Ethernet Capability

- NTP time server for high accuracy network time synchronization.
- Simultaneous DNP3 over Ethernet and Modbus TCP/IP Communication.



- See page 5 for INP100S card details.

2. INP300S: IEC 61850 Protocol Ethernet Card

- Multiple logical nodes; configurable .CID file.
- See page 5 for INP300S card details.



3. 1mAOS: Four Channel Bi-directional 0-1 mA Outputs

- Assignable to any parameter.
- 0.1% of full scale.
- Max. load impedance 10 kΩ.



4. 20mAOS: Four Channel 4-20 mA Outputs

- Assignable to any parameter.
- 0.1% of full scale.
- 850 Ω at 24 V DC.
- Loop powered using up to 24 V DC.



5. PO1S: Four Pulse Outputs / Four Status Inputs

- Programmable to any energy parameter and pulse value.
- Form A: Normally open contacts.
- Also used for end of interval pulse.



6. RO1S: Two Relay Outputs / Two Status Inputs*

- 250 V AC / 30 V DC - 0.25 A relays, Form C.
- Trigger on user set alarms.
- Set delays and reset delays.



7. FOVPS or FOSTS: Fiber Optic Card

- EIG's exclusive fiber optic daisy chain switchable built-in logic mimics RS485 half duplex bus. This lets you daisy chain meters for lower installation costs; full duplex is also assignable. This feature requires the software to ignore echoes.
- ST terminated option (-FOSTS).
- Versatile link terminated option (-FOVPS).
- Modbus and DNP3 protocols available.



Field-Expandable I/O Slots

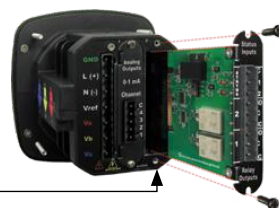

Meter Auto Detects I/O Card Type

Simple Field Upgrade

Note: I/O cards can be ordered separately - see last page.

*The meter must be at V-Switch™ key 4 or higher to use the relay features.

100BaseT Ethernet

Simultaneous Data Connections

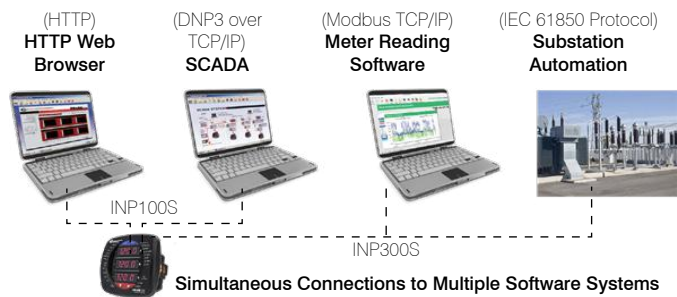

INP100S - Web Server, Modbus, DNP3, and Email

- Web server.
- Smartphone compatible.
- 12 Connections of Modbus TCP/IP.
- 5 Connections of DNP3 over TCP/IP.
- Email on alarm and periodic email notification of meter status and readings.

INP300S - Web Server, Modbus, DNP3, and IEC 61850

- IEC 61850 protocol.
- 5 Modbus connections.
- 5 MMS clients.
- Web server for status and configuration.
- Simultaneous Modbus, DNP3 over Ethernet, and IEC 61850.

Both INP100S and INP300S are dual Ethernet port capable and offer enhanced security through the Exclusive Client feature, to protect from unauthorized programming.

EnergyPQA.com[®] AI Driven Energy Management System

The EnergyPQA.com[®] system provides energy analytics and predictions enterprise wide and deep insights into power quality.

- Increase energy usage efficiency by analyzing load disaggregation and usage comparisons.
- Perform cost allocation and submetering by properly billing for actual energy usage versus square footage estimations.
- Analyze enterprise carbon footprint to determine and improve impact on the environment.

Designed for High Reliability and Ease of Use

- Ruggedly designed to withstand harsh electrical environments.
- Industrial grade components.
- Designed to the highest surge withstand and transient standards.
- Detailed circuit board testing and automation to ensure 100% reliability.
- Bright-red, three 0.56" line LED display for easy meter reading in any environment.
- Short-circuit safe current inputs with dual input methods ensure that CT connections will not open in a fault condition.

Shark[®] 200 Meter ANSI and DIN Mounting for Easy Retrofit

The unit mounts directly in an ANSI C39.1 (4" round form) or an IEC 96 mm DIN square form. This is perfect for new installations and for existing panels. In new installations, simply use DIN or ANSI punches. For existing panels, pull out old analog meters and replace them with the Shark[®] 200 meter. The meter uses standard voltage and current inputs so that CT and PT wiring does not need to be replaced.

Shark[®] 200T Transducer

This transducer version of the Shark[®] 200 meter does not include a display. The unit mounts directly to a DIN rail and provides an RS485 Modbus or DNP3 output and the expandable I/O.

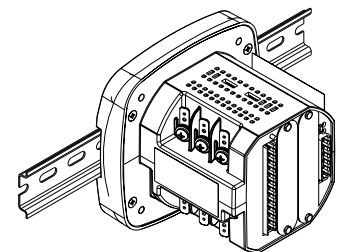

Easy DIN Rail Mounting

Typical Substation Solutions

Substation Voltage and Frequency Recording

Traditionally, voltage recording meters were relegated to high cost metering or monitoring solutions. Place the Shark® 200 meter throughout an electrical distribution network to implement one of the industry's lowest cost methods of collecting voltage information within a utility power distribution grid.

- Perform voltage reliability analysis to ensure proper voltage to customers.
- Compare voltage reliability throughout transmission or distribution networks.
- Monitor the output of substation transformers or line regulators.
- Initiate conservation voltage reduction, reducing system demand.

- Monitor highly accurate frequency to regulate frequency stability.
- Replace costly frequency transducers.

Low Cost Substation Telemetry

Bring back data using many different communication media, such as RS485, Ethernet, and analog outputs. One meter can be used for almost every substation application, no matter what communication infrastructure is needed.

- Perfect for new or retrofit applications.
- Multiple communication paths.
- One meter provides outputs for every application.
- Multiple systems and/or users can access data simultaneously.

Interval Load Profiling

Log substation data over time for electrical usage, demand, voltage, current, PF, and many other parameters. This enables a complete analysis of the power system over time.

- Provide revenue accurate load profiling.
- Determine substation usage.
- Analyze feeder capacity and utilization.
- Provide time-based load profile for planning and estimation.
- Data trend PF distribution and imbalances for system efficiency analysis.

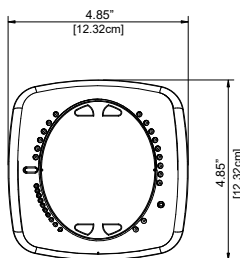

SHARK® 200 FRONT DIMENSIONS

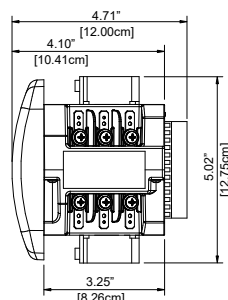

SHARK® 200 SIDE DIMENSIONS

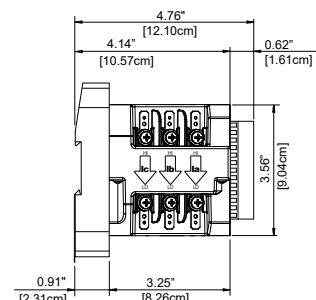

SHARK® 200T SIDE DIMENSIONS

Wiring Diagrams and Specifications

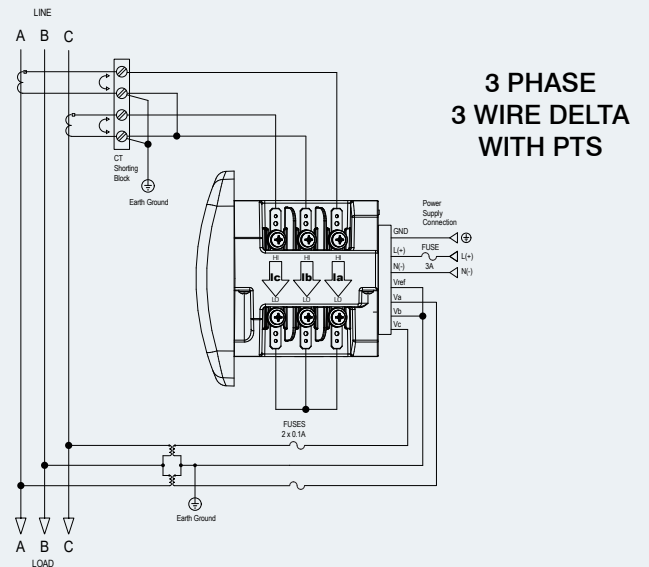
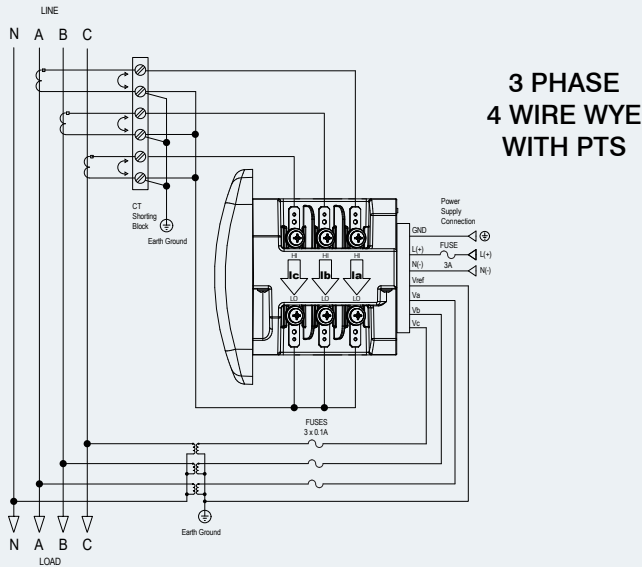
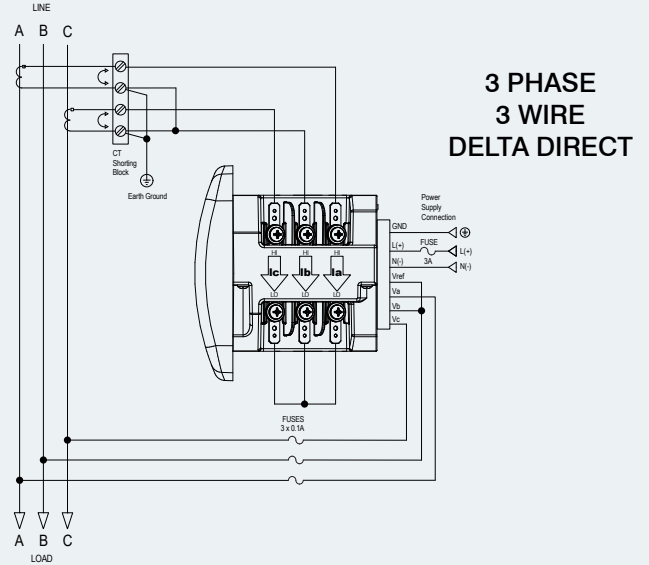
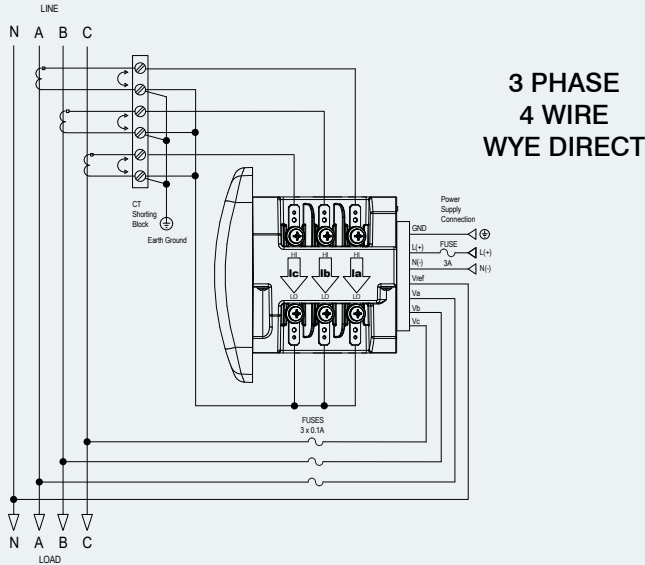

Voltage Inputs

- Absolute Range: (20-576) Volts Line to Neutral, (0-721) Volts Line to Line
- Universal Voltage Input
- Input Withstand Capability – Meets IEEE C37.90.1 (Surge Withstand Capability)
- Programmable Voltage Range to Any PT Ratio
- Supports: 3 Element WYE, 2.5 Element WYE, 2 Element Delta, 4 Wire Delta Systems
- Input Impedance 1 MΩ/Phase
- Burden: 0.36 VA/Phase at 600V; 0.014 VA at 120 Volts
- Input Wire Gauge: AWG#12 -26(0.129 -3.31) mm2

Current Inputs

- Class 10: (0.005 to 10) A, 5 A Nominal CT Secondary
- Class 2: (0.001 to 2) A, 1 A Nominal CT Secondary
- Fault Current Withstand (at 23 °C): 100 A for 10 Seconds, 300 A for 3 Seconds, 500 A for 1 Second

- Continuous Current Withstand: 20 A for Screw Terminated or Pass Through Connections
- Programmable Current to Any CT Ratio
- Burden 0.005 VA per Phase Max at 11 A
- Pickup Current: 0.1% of Nominal (Class 10: 5 mA; Class 2: 1 mA)
- Pass Through Wire Diameter: 0.177" / 4.5 mm

Isolation

- All Inputs and Outputs are Galvanically Isolated to 2500 Volts

Environmental Rating

- Storage: (-20 to +70) °C
- Operating: (-20 to +70) °C
- Humidity: to 95% RH Non-Condensing
- Faceplate Rating: NEMA 12
- Mounting Gasket Included
- Protection: IP30 - Meter Front/Back, Optional DIN Rail Mounting, Optional Plug-in I/O Modules

Sensing Method

- True RMS
- Sampling at Over 400 Samples/Cycle

on all Channels of Measured Readings Simultaneously

- Harmonics Resolution to 40th Order
- Waveform up to 512 Samples/Cycle

Update Rate

- Watts, VARs, and VA - Every 6 Cycles
- All Other Parameters - Every 60 Cycles

Power Supply

- Option D2: (90-265) V AC @ 50/60 Hz or (100-370) V DC/ 10 VA Max
- Option D: (18-60) V DC (24 to 48 V DC Systems) / 7 W Max

Standard Communication Format

- 2 Com Ports (Back and Faceplate)
 - RS485 Port through Backplate
 - IrDA through Faceplate
- Com Port Baud Rate: (1200 - 57600)
- Com Port Address: 1-247
- 8-Bit, Parity Setting: Odd, Even, None
- Modbus RTU, ASCII, or DNP3 Protocols

KYZ Pulse

- Type Form C Contact
- On Resistance: 35 Ohms Max
- Peak Voltage: 350 V DC

- Continuous Load Current: 120 mA

- Peak Load Current: 350 mA (10 ms)
- Off State Leakage Current @350 V DC: 1uA

Dimensions and Shipping

- Weight: 2 lbs / .91 kg
- Basic Unit: H4.85" x W4.85" x L4.25"
- Shark® 200 Meter Mounts in 96 mm DIN & ANSI C39.1 4" Round Cutouts
- Shark® 200T Transducer: DIN Rail Mounted Using Attached DIN Rail Clips
- Shipping Container Dimensions: 6" Cube

Meter Accuracy

- See Page 2
- **Note:** For 2.5 element programmed units, degrade accuracy by an additional 0.5% of reading.
- **Note:** For 1A (Class 2) Nominal, degrade accuracy to 0.5% of reading for watts and energy; all other values 2 times rated accuracy.

Compliance

- ANSI C12.20 0.2 Accuracy Class and C12.1 (MET Labs Certified)*
- ANSI C62.41 (Burst)*
- FCC, Part 15, Subpart B, Class A (Radiated and Conducted Emissions)*
- IEC 62053-22 Accuracy, 0.2S (KEMA Laboratories Certified) *
- IEC 62053-23 Edition 1, Class 2

- EN 61000-6-2 – Immunity for Industrial Environments: 2005
- EN 61000-6-4 – Emission Standards for Industrial Environments: 2007
- CE (EN 61326-1*, EN 61000-6-2, EN 61000-6-4)
 - EN 61000-3-2, Class A (Harmonic Current)*
 - EN 61000-3-3 (Voltage

- Fluctuation and Flicker)*
- IEC 61000-4-2, Ed.1.2, Class A (Electrostatic Discharge)*
- IEC 61000-4-3, Class A (Radiated EM Immunity)*
- IEC 61000-4-4, Second Ed., Class A (EFT)*
- IEC 61000-4-5, Ed. 1.1, Class A (Surge Immunity)*
- IEC 61000-4-6 (Conducted

- Immunity)*
- IEC 61000-4-8, Class A (Magnetic Immunity)*
- IEC 61000-4-11, Class A (Voltage Variations Immunity)*
- IEC/CISPR11, Ed.4.1 (Radiated Emissions)*
- CISPR22, Class A, Fifth Ed. *
- IEC 61850 (KEMA Laboratories Certified)*

- IEEE C37.90.1 (Surge Withstand Capability)
 - Certified to UL/IEC 61010-1 and CSA C22.2 No. 61010-1, UL File: E250818*
 - REACH/RoHS 3 Directive 2011/65/EU
 - New York State approved for residential metering
- *Third party lab certified.

Ordering Information - All fields must be filled in to create a valid part number.

	Model	Frequency Range	Current Input	V-Switch™ Pack	Power Supply	I/O Slot 1*	I/O Slot 2*	Mounting (Shark® 200 Meter)
Option Numbers:	-	-	-	-	-	-	-	-
Example:	Shark200	60	10	V2	D2	INP100S	X	X
	Shark200 (Meter/Transducer)	60 60 Hz System	10 5 A Nominal CT Secondary	V1 Multifunction Meter Only	D2 (90-265) V AC @ 50/60 Hz or (100-370) V DC	X None	X None	X ANSI Mounting
	Shark200T (Transducer Only)	50 50 Hz System	2 1 A Nominal CT Secondary	V2 Standard Data Logging Memory	D (18-60) V DC	RO1S** 2 Relays/2 Status	RO1S** 2 Relays/2 Status	DIN DIN Mounting Brackets
				V3 Power Quality Harmonics		PO1S 4 Pulses/4 Status	PO1S 4 Pulses/4 Status	
				V4 Limits & Control		1mAOS 4 Channel Analog Output 0-1 mA (bidirectional)	1mAOS 4 Channel Analog Output 0-1 mA (bidirectional)	
				V5 64 Samples/Cycle Waveform Recording		20mAOS 4 Channel Analog Output 4-20 mA	20mAOS 4 Channel Analog Output 4-20 mA	
				V6 512 Samples/Cycle Waveform Recording		FOSTS Fiber Optic Output VPIN terminated	FOSTS Fiber Optic Output VPIN terminated	
						FOVPS Fiber Optic Output VPIN terminated	FOVPS Fiber Optic Output VPIN terminated	
						INP100S 100BaseT Ethernet	INP100S 100BaseT Ethernet	
* I/O cards can be ordered separately using the part numbers shown in the ordering information.			** The meter must be at V-Switch™ key 4 or higher to use the relay features.			INP300S IEC 61850 Protocol Ethernet	INP300S IEC 61850 Protocol Ethernet	

Accessories

Software		Communication Converters	
COMPQA6P1Y	CommunicatorPQA® 6 Software for Windows Single-Computer License (One Year)	E205301	RS485 to USB Converter
Unicom 2500			RS485 to RS232 Converter
EnergyPQA-1Year	AI Driven Energy Management System	CAB6490	USB to IrDA Adapter
Unicom 2500-F			RS485 to RS232 to Fiber Optic Converter

1800 Shames Drive
Westbury, NY, 11590

1-877-EIMETER
(1-877-346-3837)

Tel: 516-334-0870
Fax: 516-338-4741

Email: EIG_sales@hubbell.com
Website: www.electroind.com

